

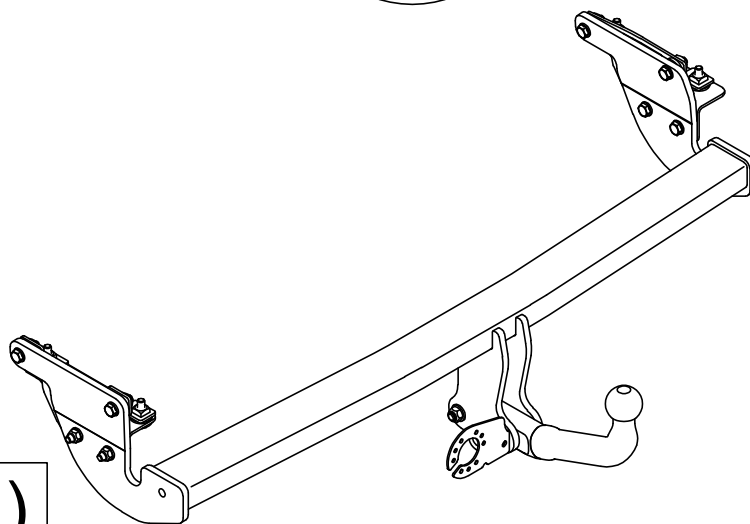

Die Anhängerkupplung.

Anhängerkupplungen  
und Elektrosätze direkt  
vom Hersteller

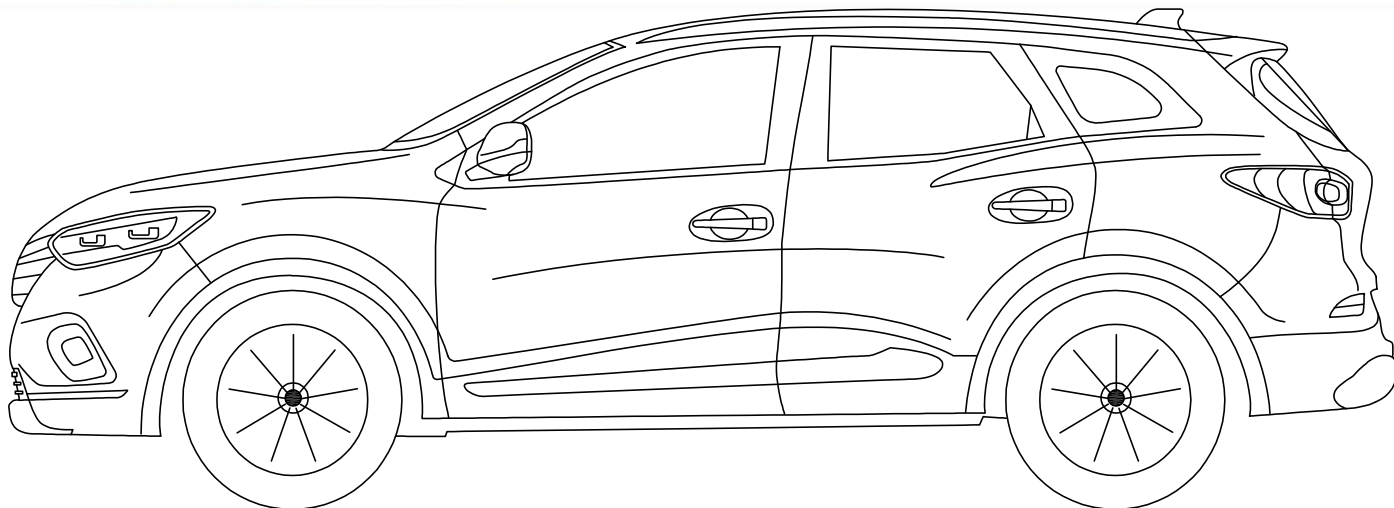

**MVG: 0979 B**

**Renault Kadjar (RFE)**

**E** Instrucciones de montaje

**D** Einbauanleitung

**GB** Installation instruction

**F** Notice de montage

**NL** Inbouw instructie

**S** Monteringsanvisning

**CZ** Návod k montáži

**I** Istruzioni di montaggio

An der Wasserwiese 1  
D-52249 Eschweiler

[info@mvg-ahk.de](mailto:info@mvg-ahk.de)  
[www.mvg-ahk.de](http://www.mvg-ahk.de)

Tel.: (02403)7902-60  
Fax: (02403)7902-99

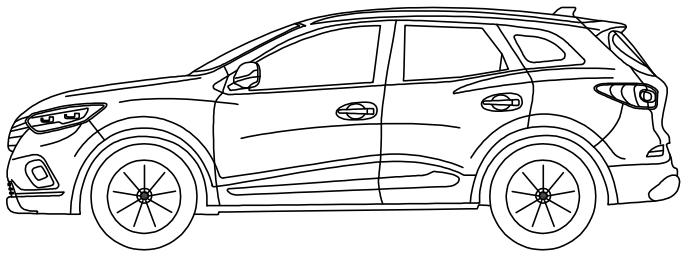

↓ ≤ 2139 kg



EG

e2 \* 2007/46 \* 0475

$$D = 10,0 \text{ kN}$$

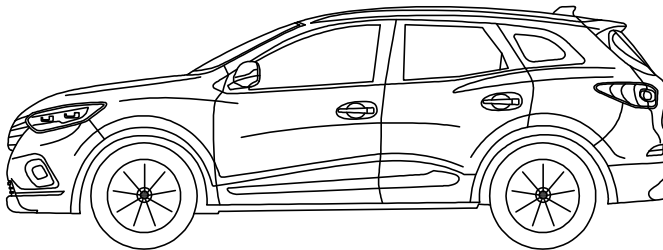

≤ 75 kg

kg ?

$$D = \frac{T \times R}{1000 \times (T + R)} \times g$$

$$g = 9,81 \text{ m/s}^2$$

$$T = \frac{R \times D \times 1000}{(g \times R) - (1000 \times D)}$$

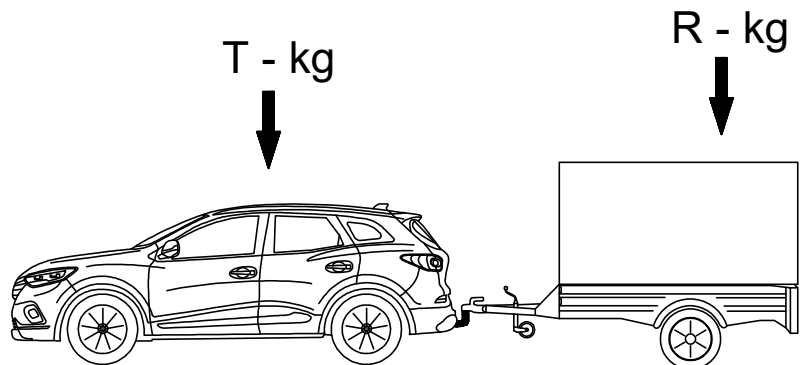

$$R = \frac{T \times D \times 1000}{(g \times T) - (1000 \times D)}$$

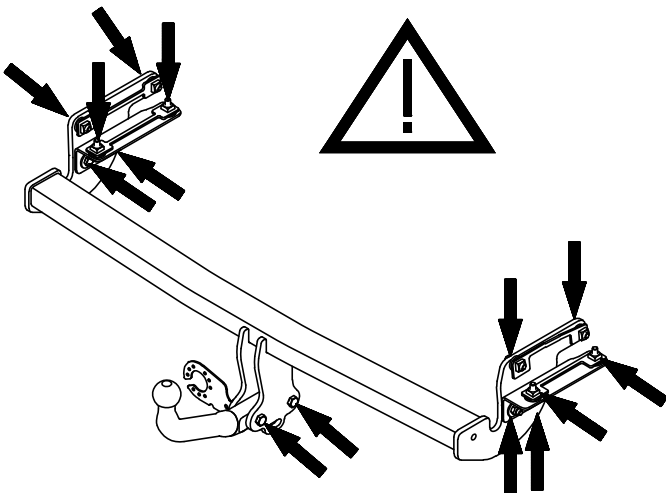
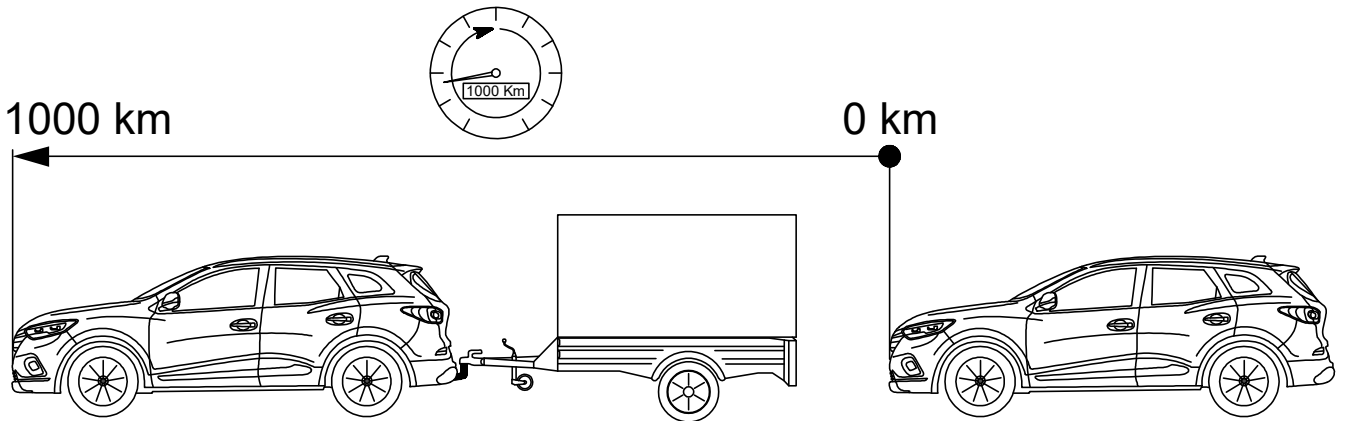
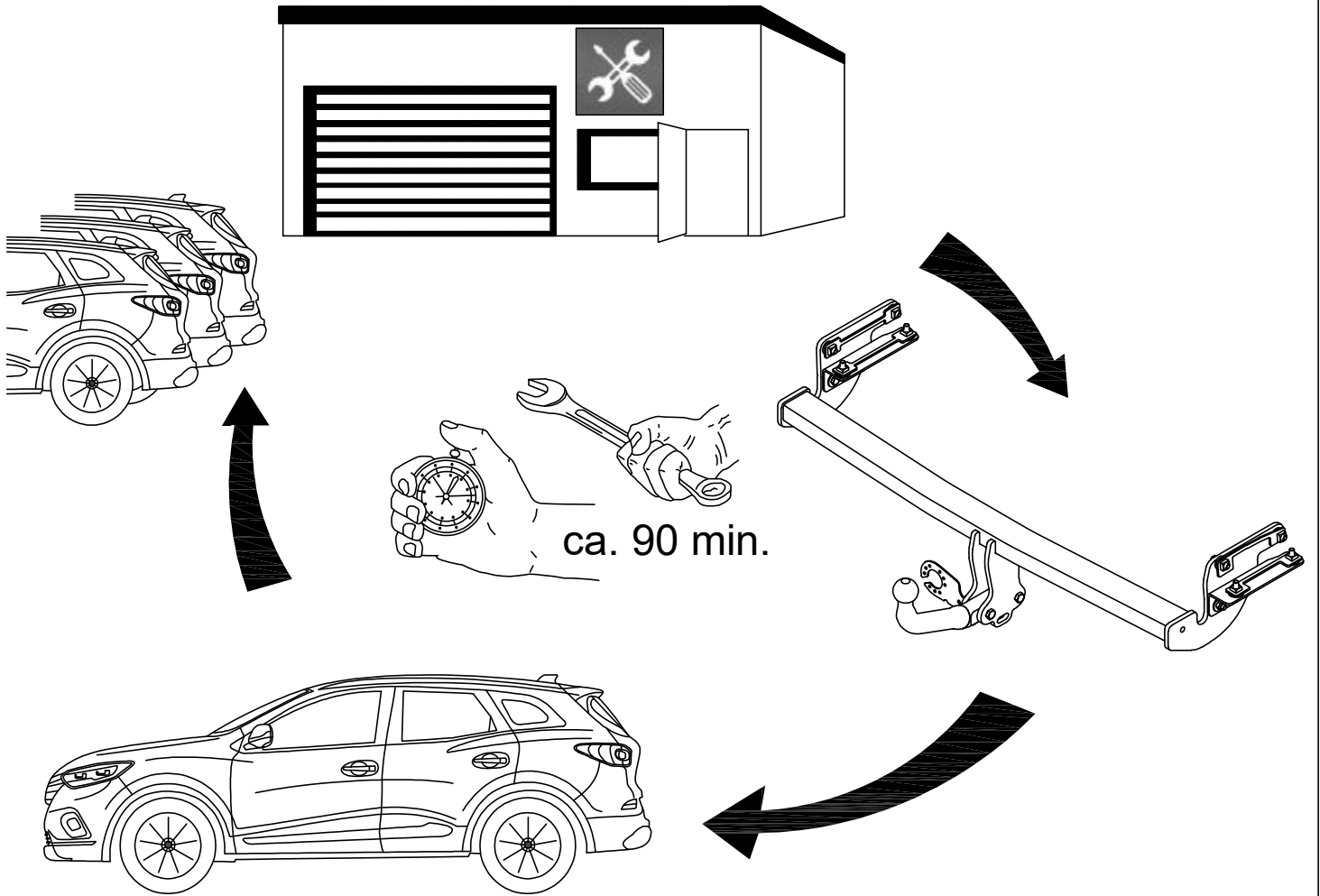

	M10	<b>60 Nm</b> <b>100 Nm</b>
	M12	

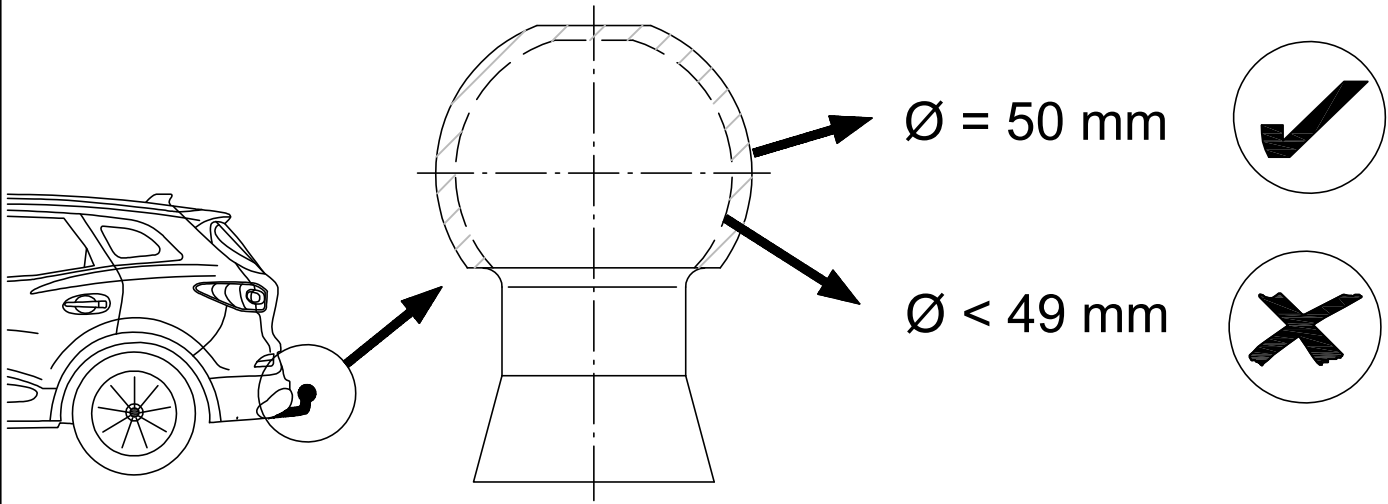

**MVG**<sup>®</sup> Approval Number  
 E4 55R-01 1114  
 MVG-Metallverarbeitungsgesellschaft mbH  
 Type: 0979 B D-Value: 10,0 kN  
 Class: A50-X S-Value: 100 kg  
 Made in Germany [www.mvg-ahk.de](http://www.mvg-ahk.de)

Zulässige Stützlast  
 maximal 75 kg

**MVG**<sup>®</sup>  
 MVG-Metallverarbeitungsgesellschaft mbH  
[www.mvg-ahk.de](http://www.mvg-ahk.de)

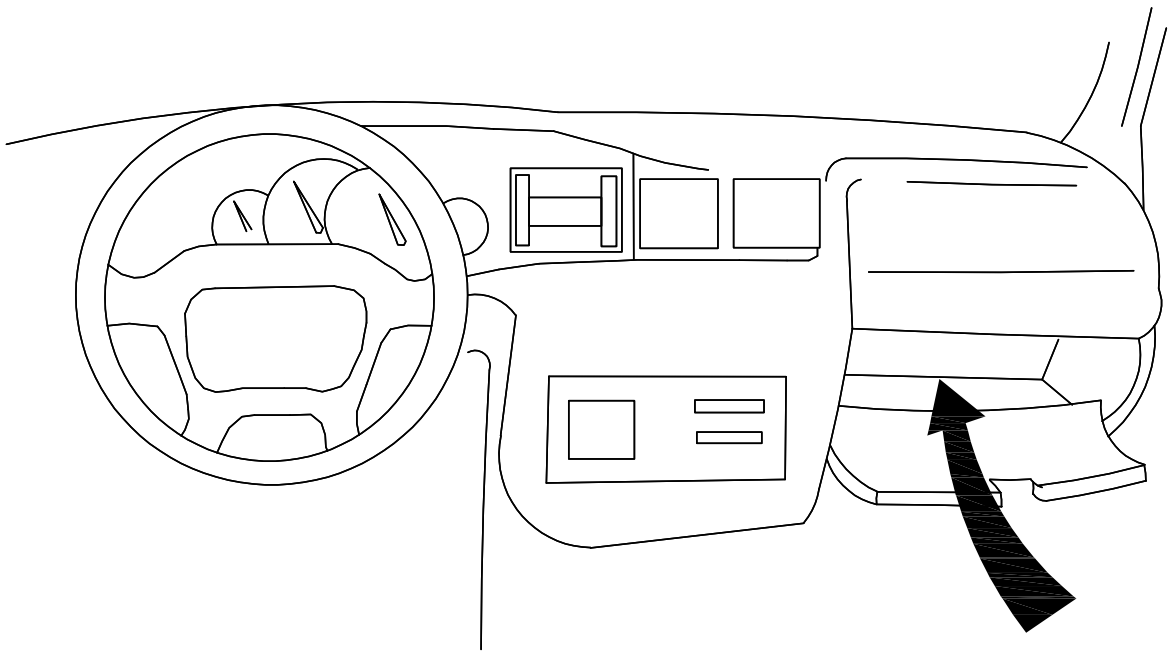

Technische Änderungen vorbehalten



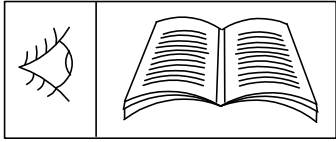

siehe Werkstatthandbuch

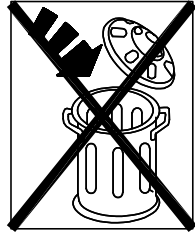

Nicht Entsorgen

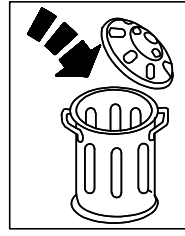

Entsorgen

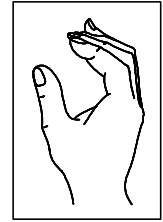

Von Hand



Achtung

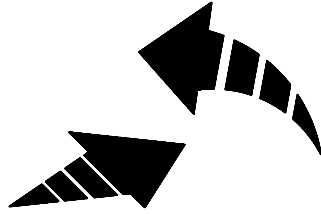

Bewegungs Pfeil



Positionspfeil

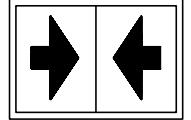
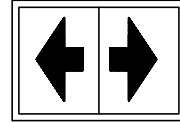

Stecker lösen/ verbinden

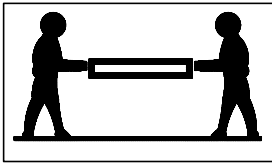

Nur zu zweit ausführen

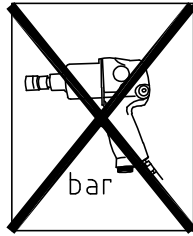

Ohne Druckluft

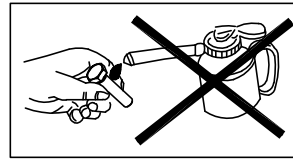

Nicht ölen

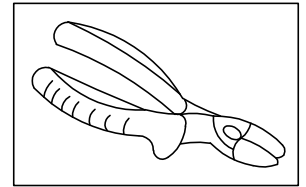

Seitenschneider verwenden

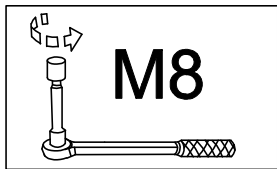

Festdrehen

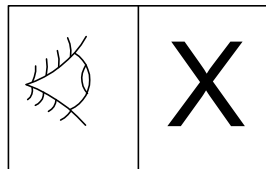

Siehe Abbildung



**CLEANER**

Reinigen

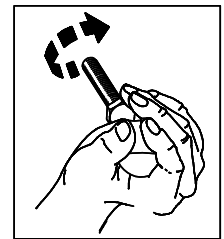

Von Hand festdrehen

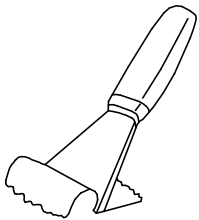

Unterbodenschutz entfernen



Gegen Korrosion schützen

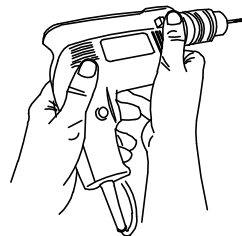

Bohrer verwenden

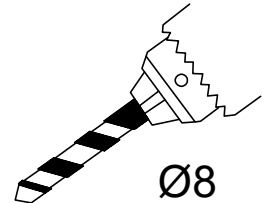

Bohrer Ø X wählen

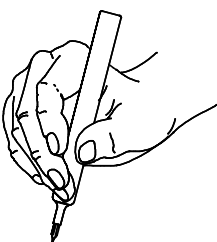

Anzeichnen

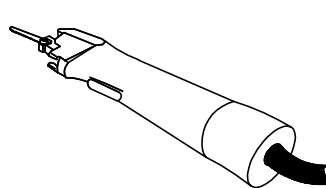



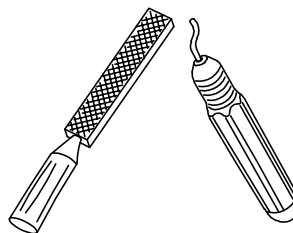



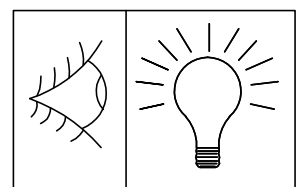



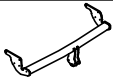





Schneiden



Feilen/ Entgraten

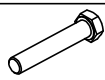

Licht kontrollieren

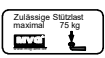
1	1x		0979 B	
2	1x		2000 B 44.0	
3	1x		(rechts)	
4	1x		(links)	
5	1x		(rechts)	
6	1x		(rechts)	
7	2x		(links)	
8	12x		M10x35 (10.9)	ISO 4017
9	12x		Ø10,5/ 30x2,5	ISO 7093
10	8x		Ø10,5/ 20x2	ISO 7089
11	4x		Ø10,5/ 28x4	DIN 6340
12	4x		M10 (10)	ISO 7042
13	1x			
14	2x		M12x70 (10.9)	ISO 4014
15	1x		Ø13/ 24x2,5	ISO 7089
16	2x		M12 (10)	ISO 7042
17	1x		0979 B	
18	1x			0062
19	je1		75 kg	1016

(E) Volumen de suministro del enganche

(D) Lieferumfang der Anhängervorrichtung

(GB) Scope of delivery of towing hitch

(F) Pièces comprises dans la fourniture de l'attelage

(NL) Leveringsomvang trekhaak

(S) Dragkrokens leveransspecifikation

(CZ) Objem dodání tažného zařízení

(I) Dotazione del gancio di traino

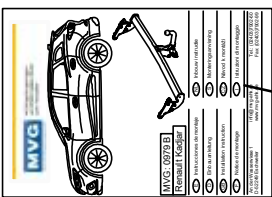

Zulässige Stützlast  
maximal 75 kg  
  
[www.mvg.de](http://www.mvg.de)

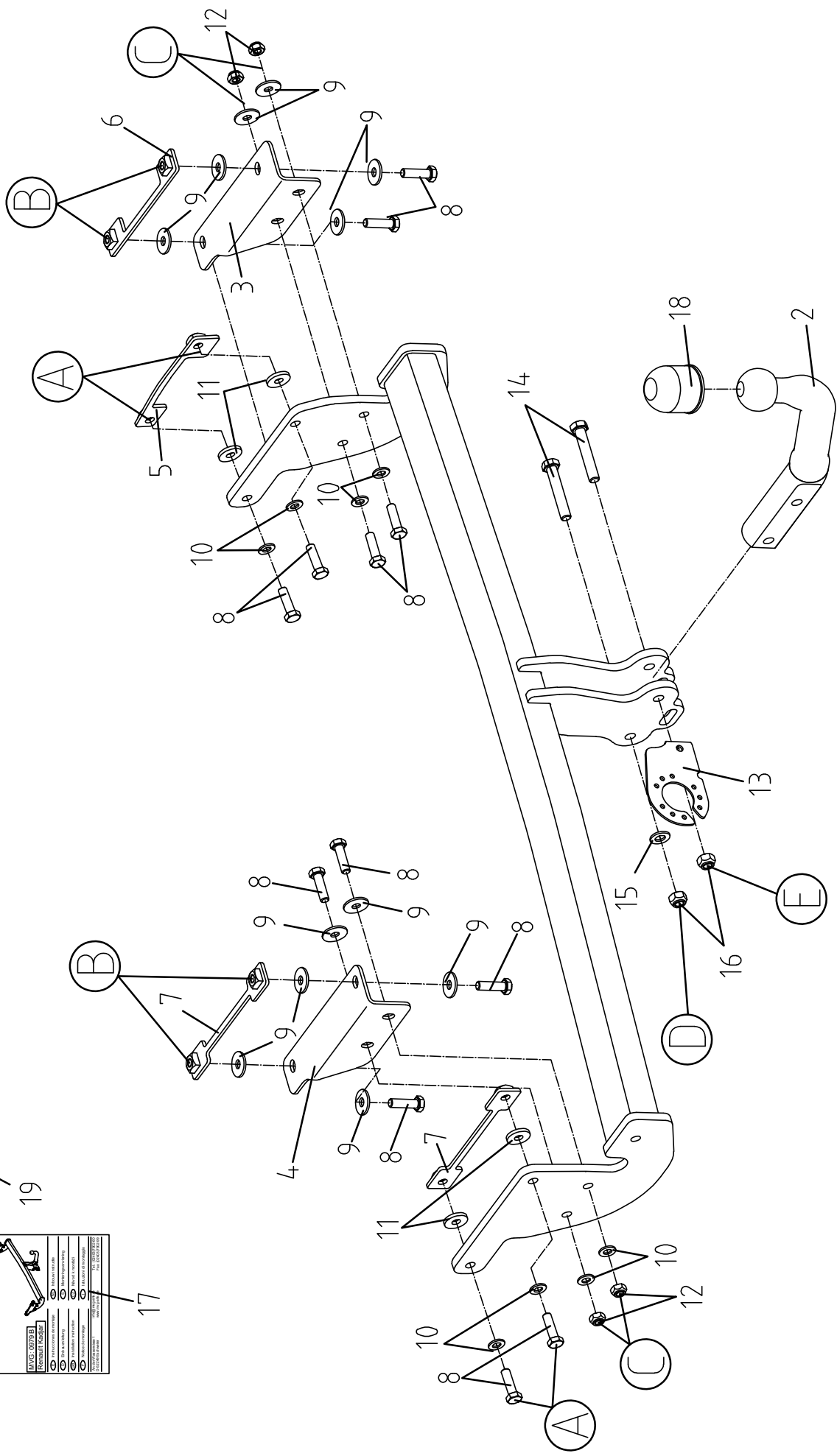

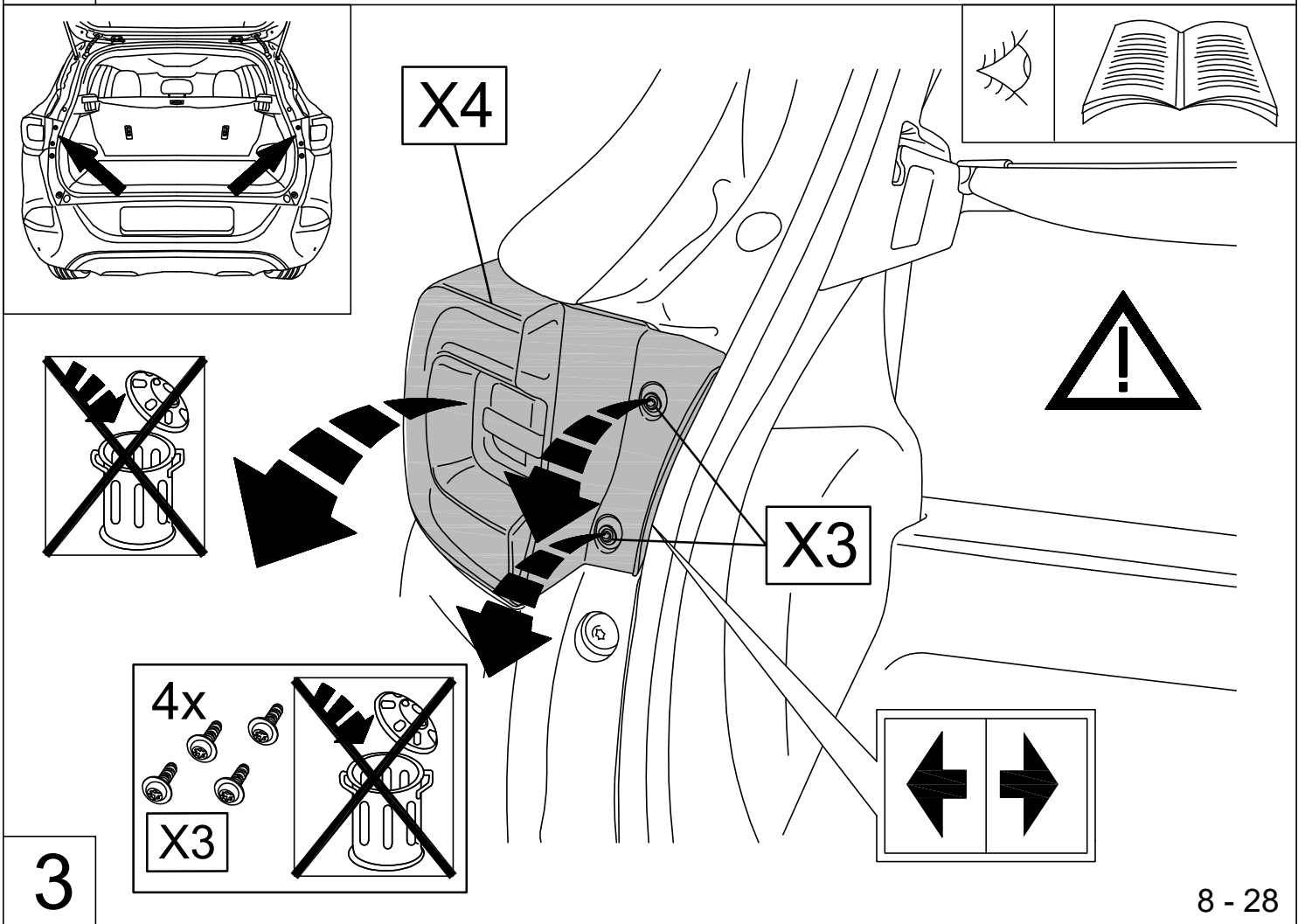
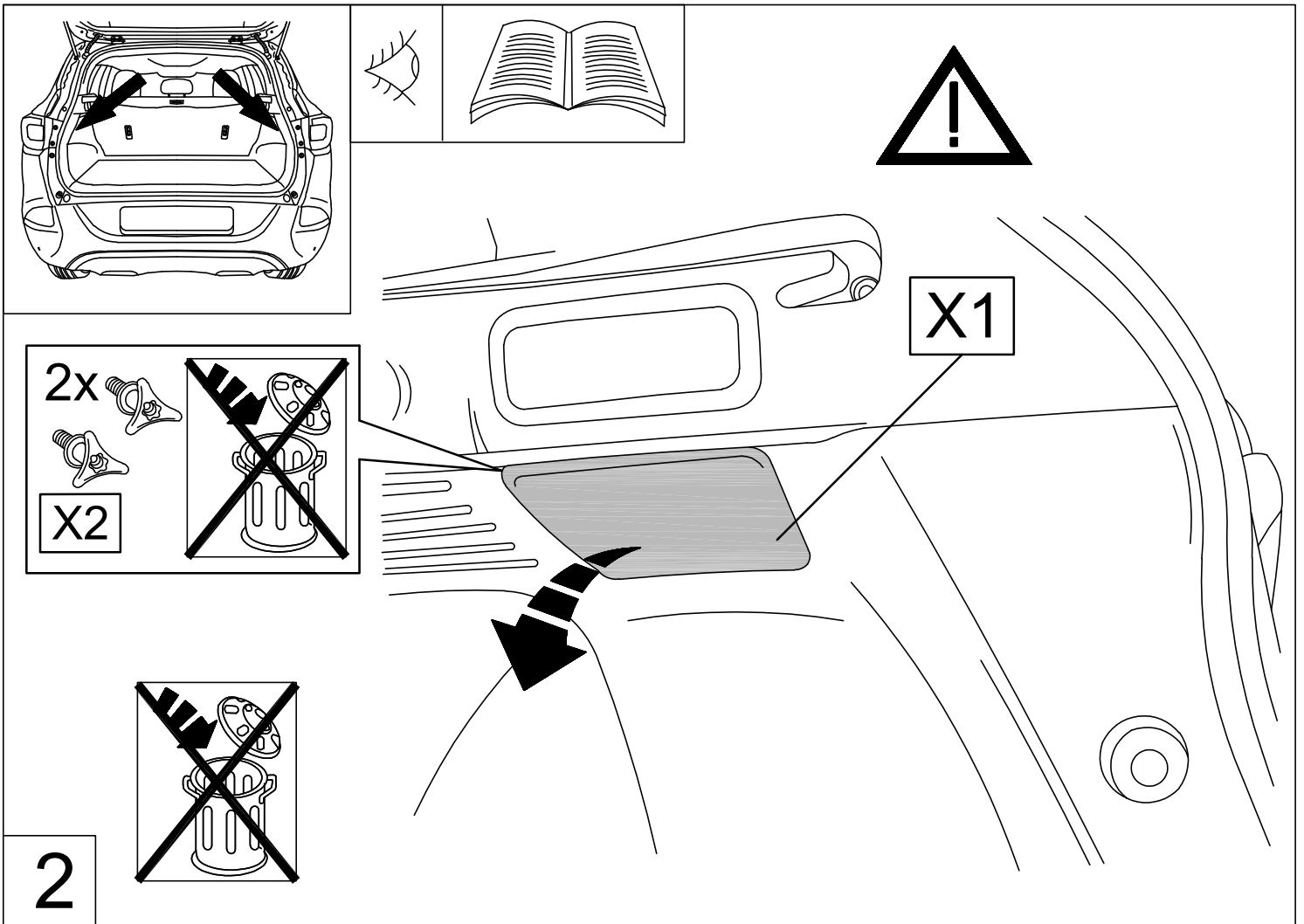



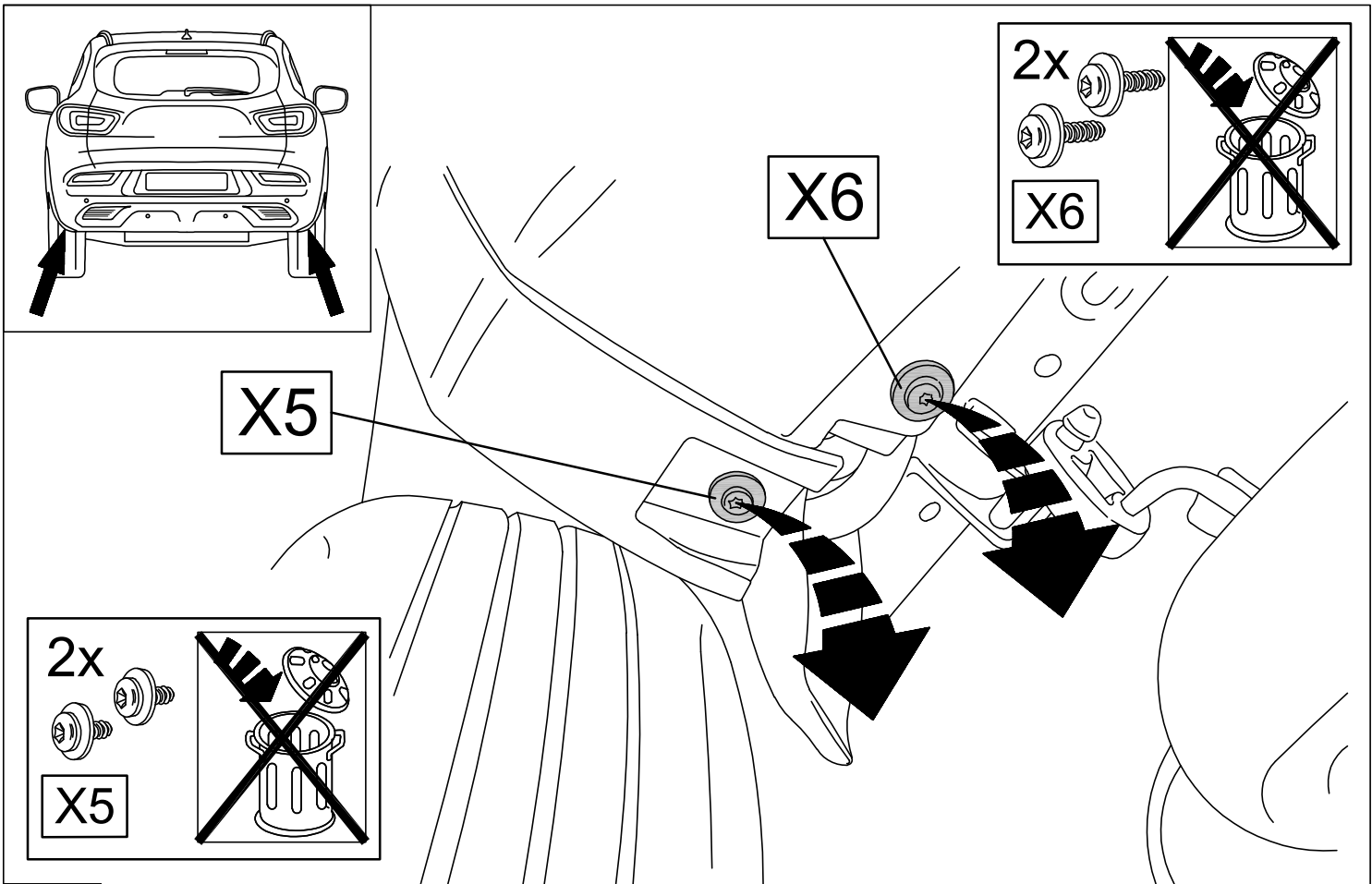

4

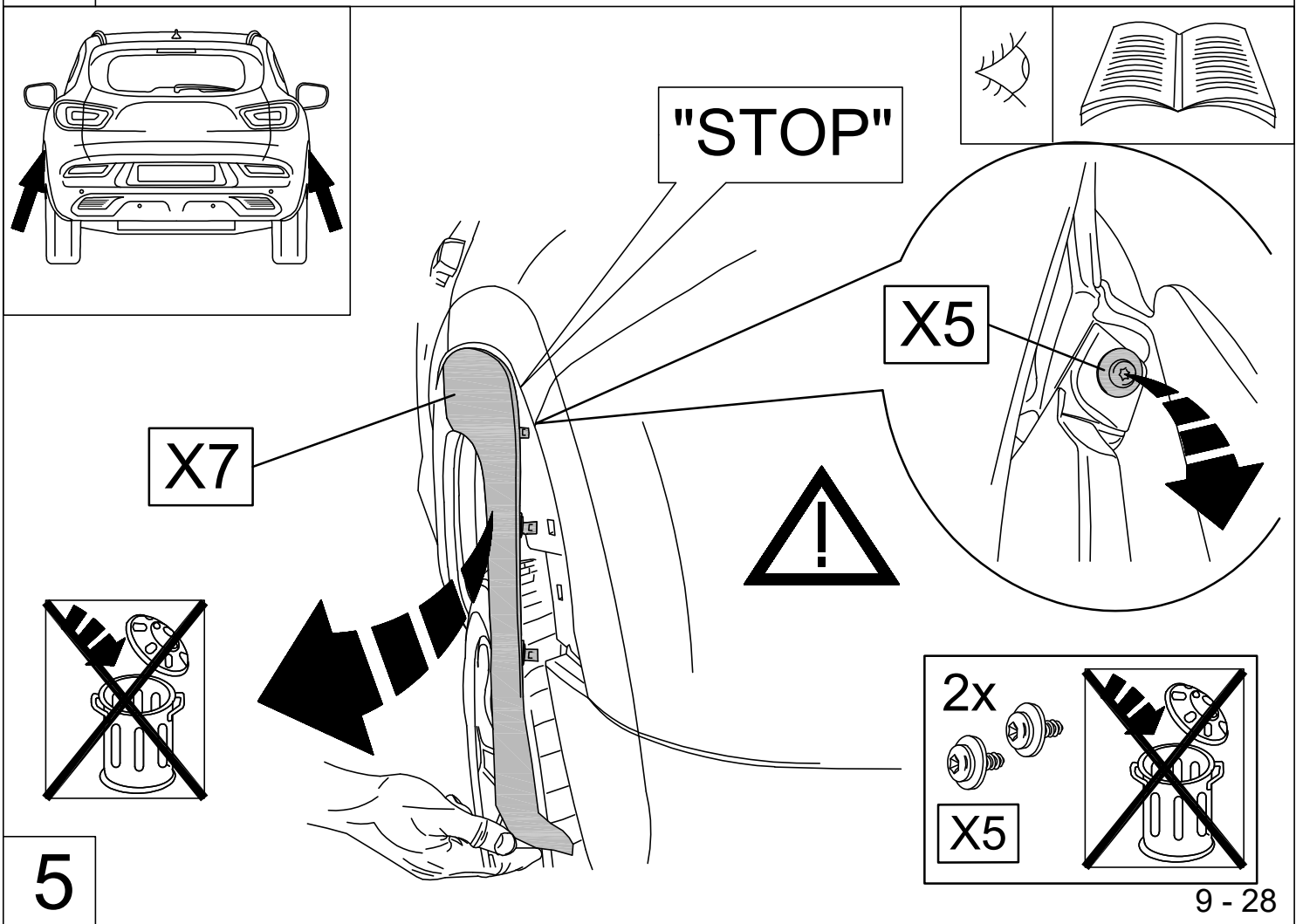

5

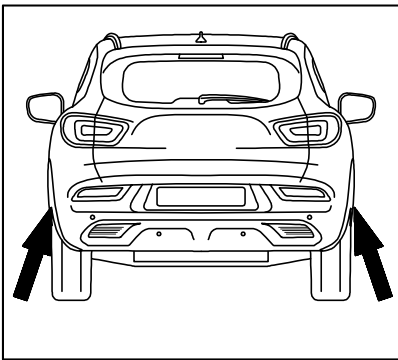

X6

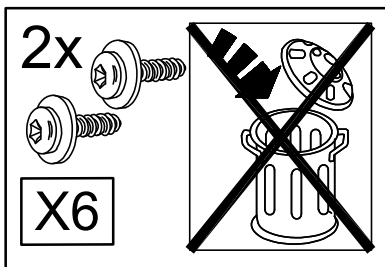
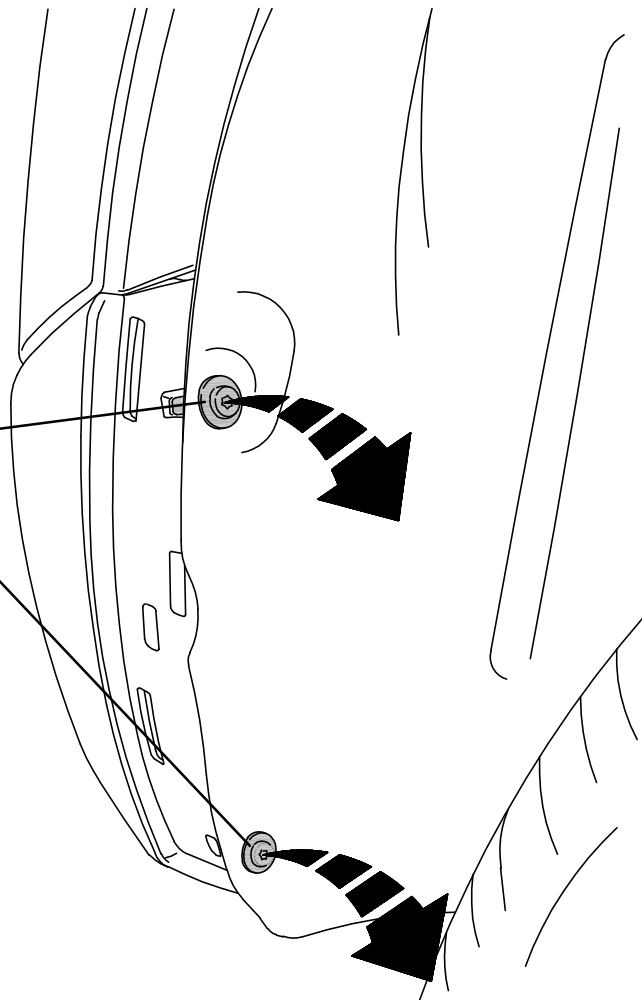

6

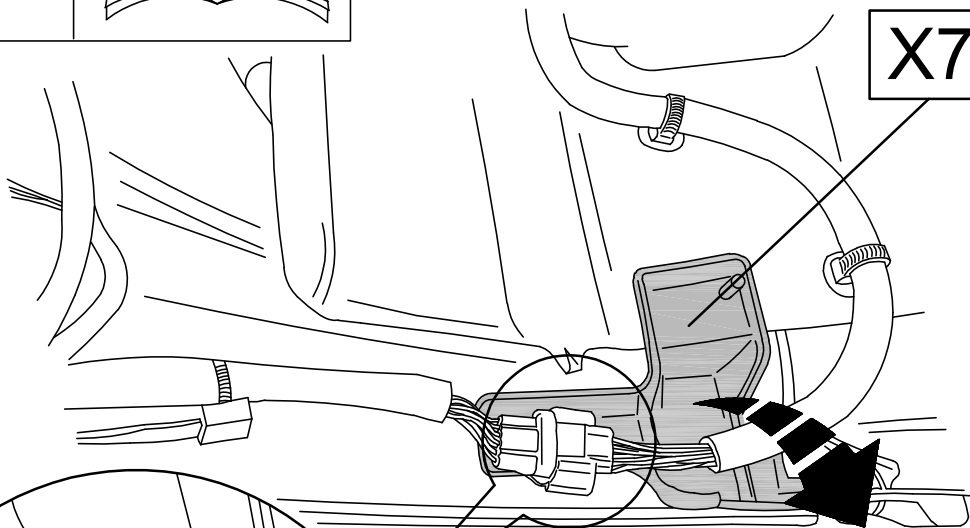
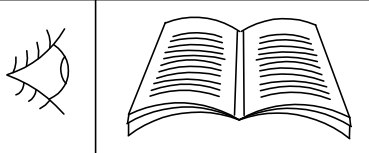
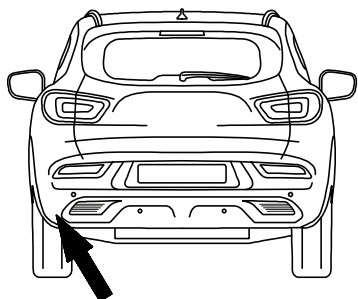

X7

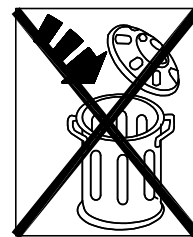
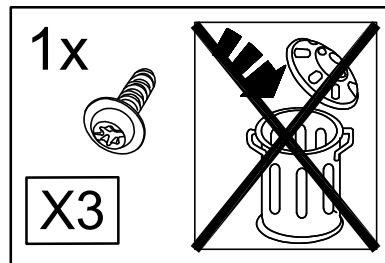
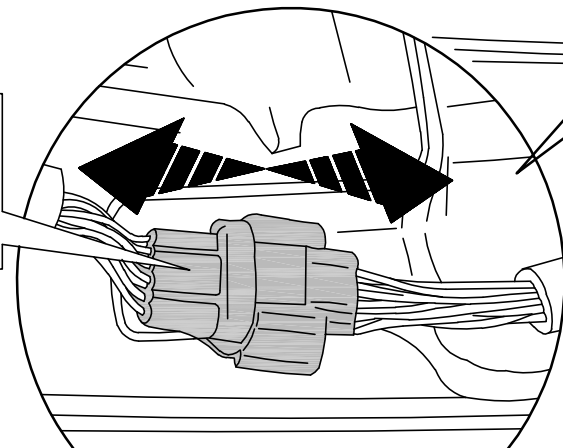
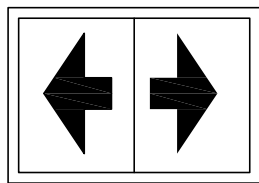

7

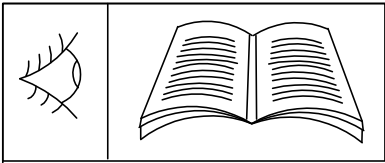

X10

X9

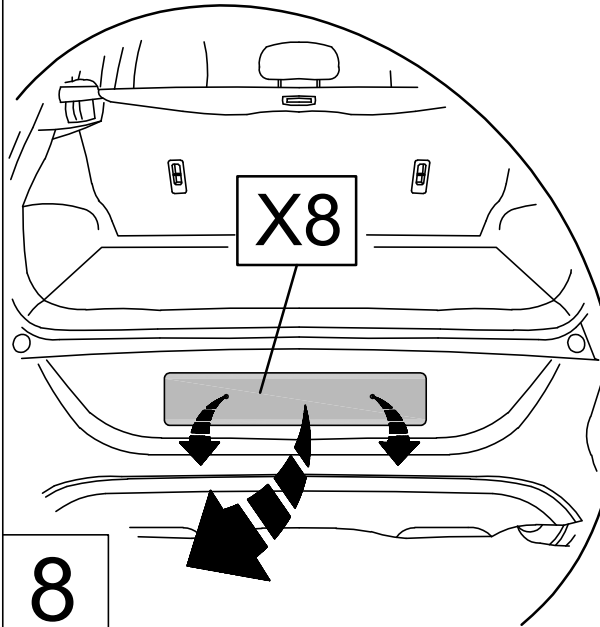

X8

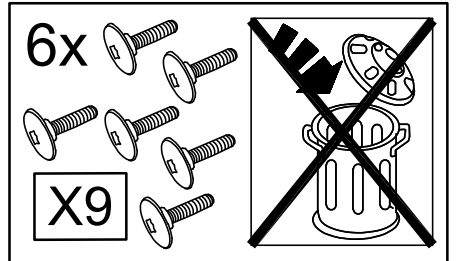
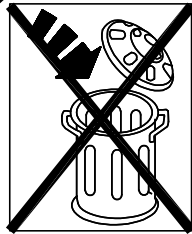
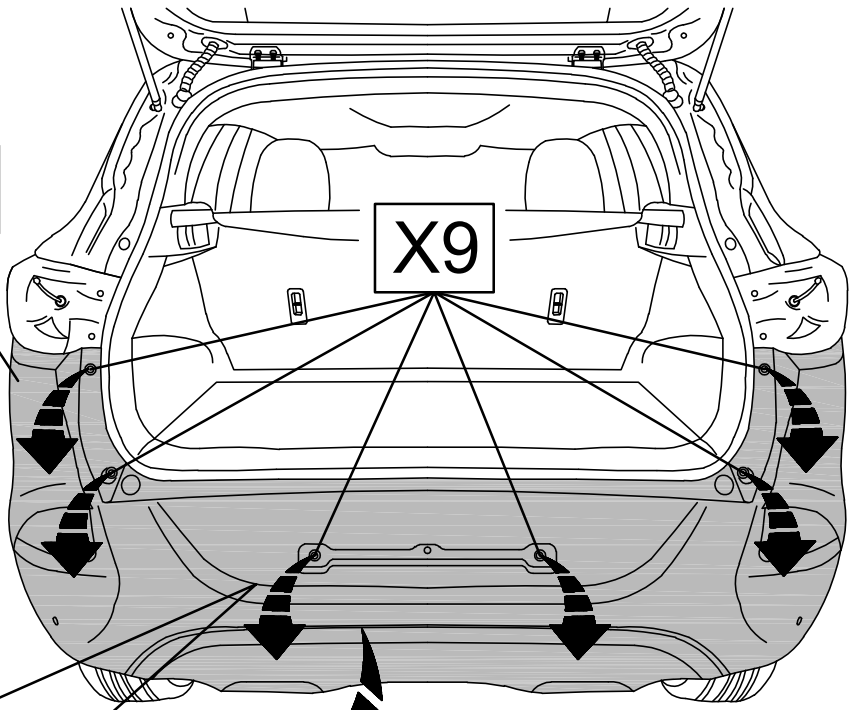

6x

X9

8

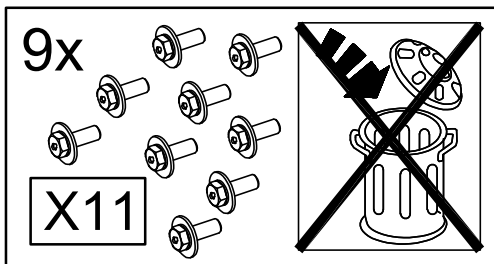

9x

X11

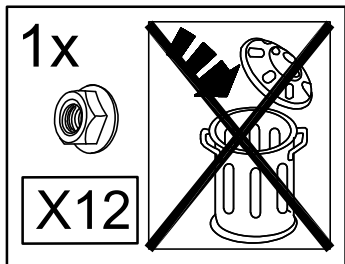

1x

X12

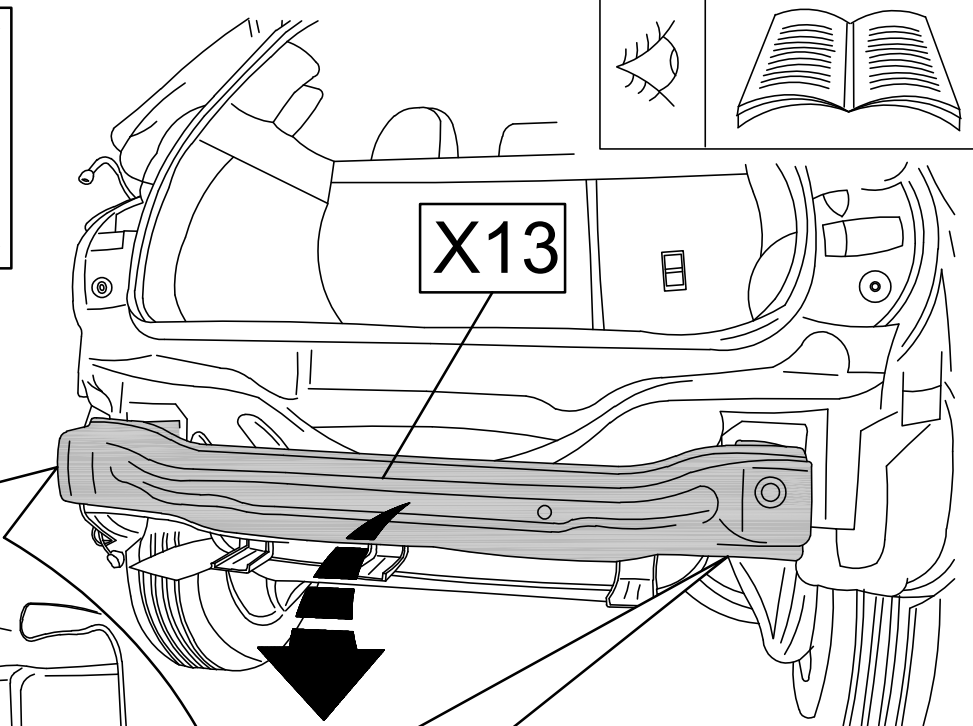

X13

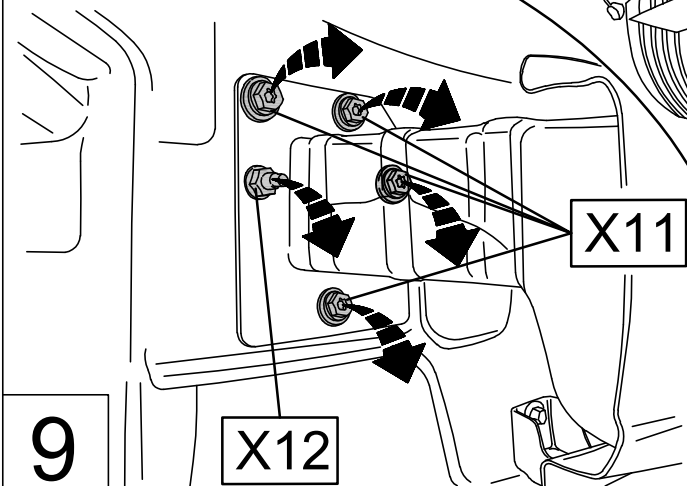

X11

X12

9

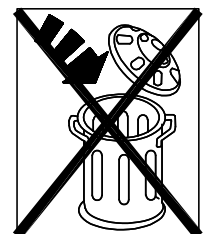

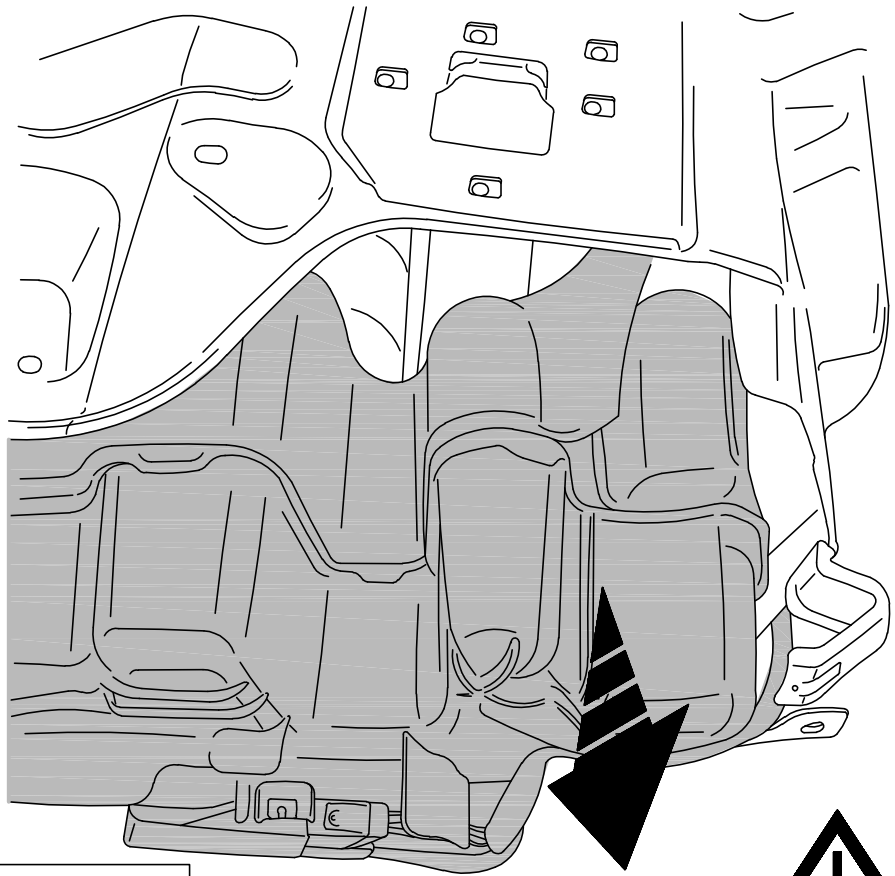
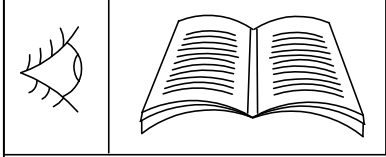
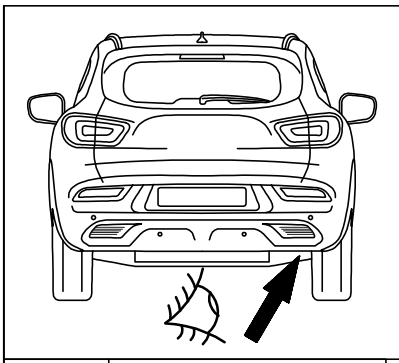

 **AdBlue**

ca. 100 mm



10

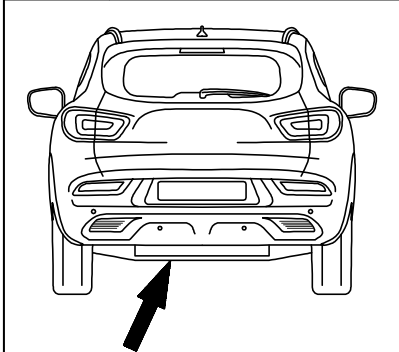

X14

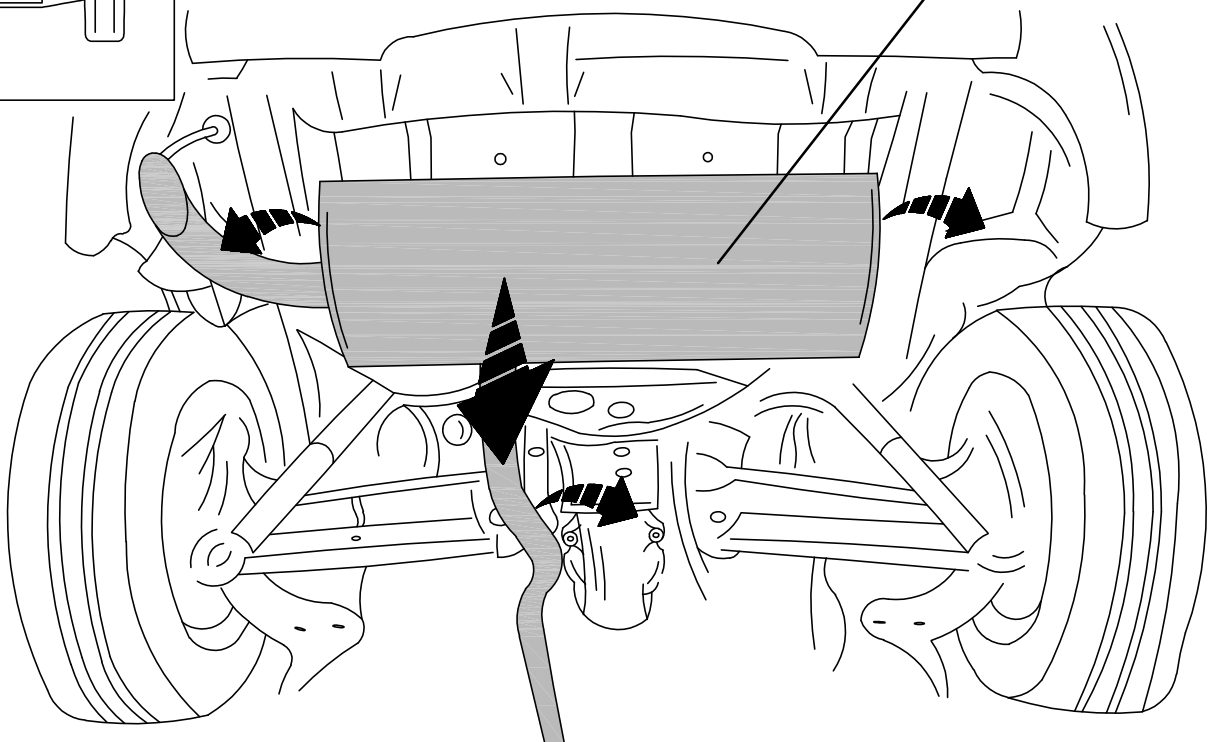

11

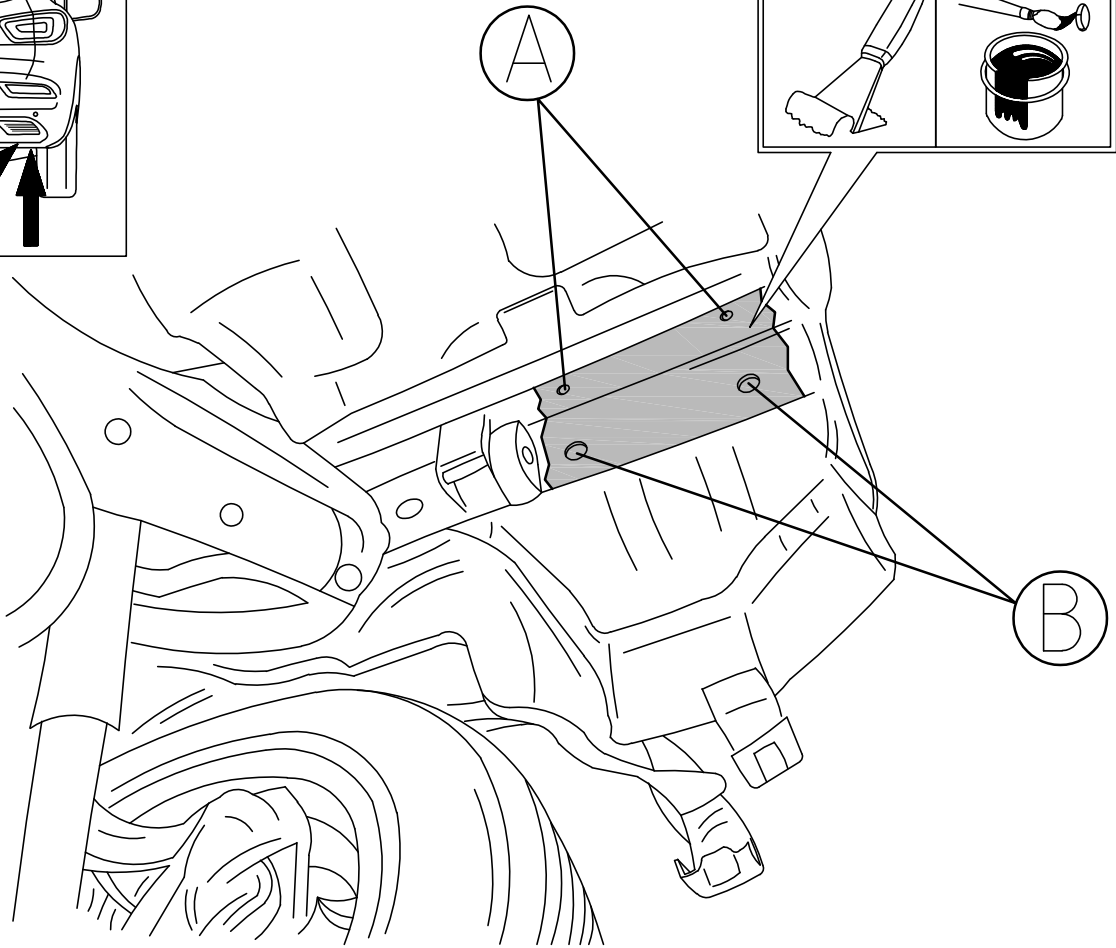
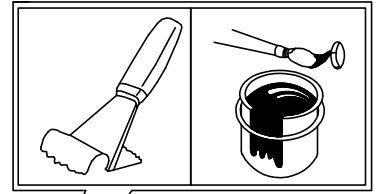
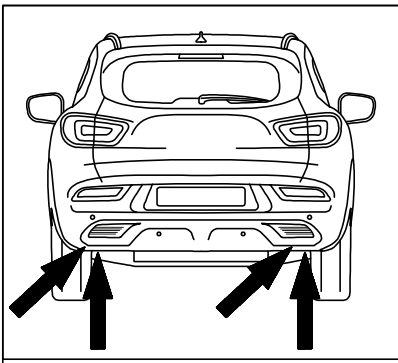

12

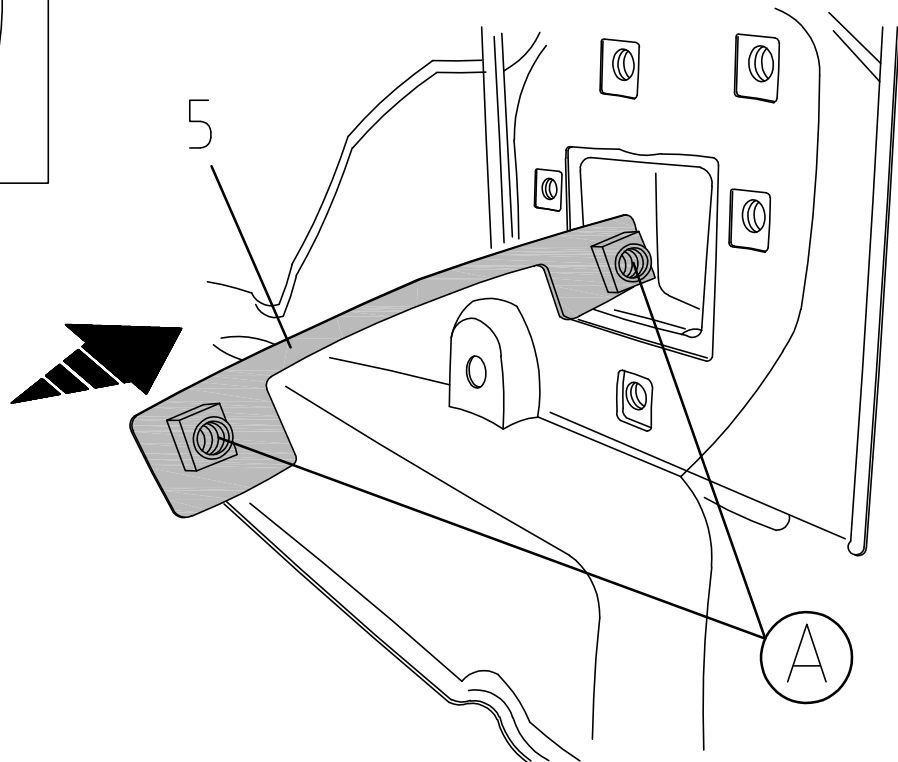
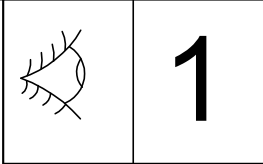
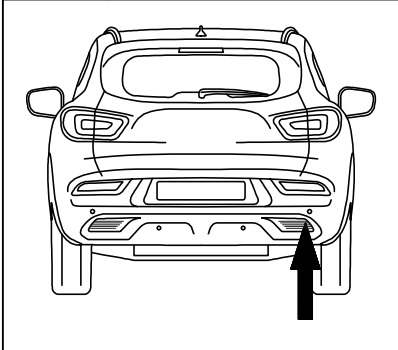

13

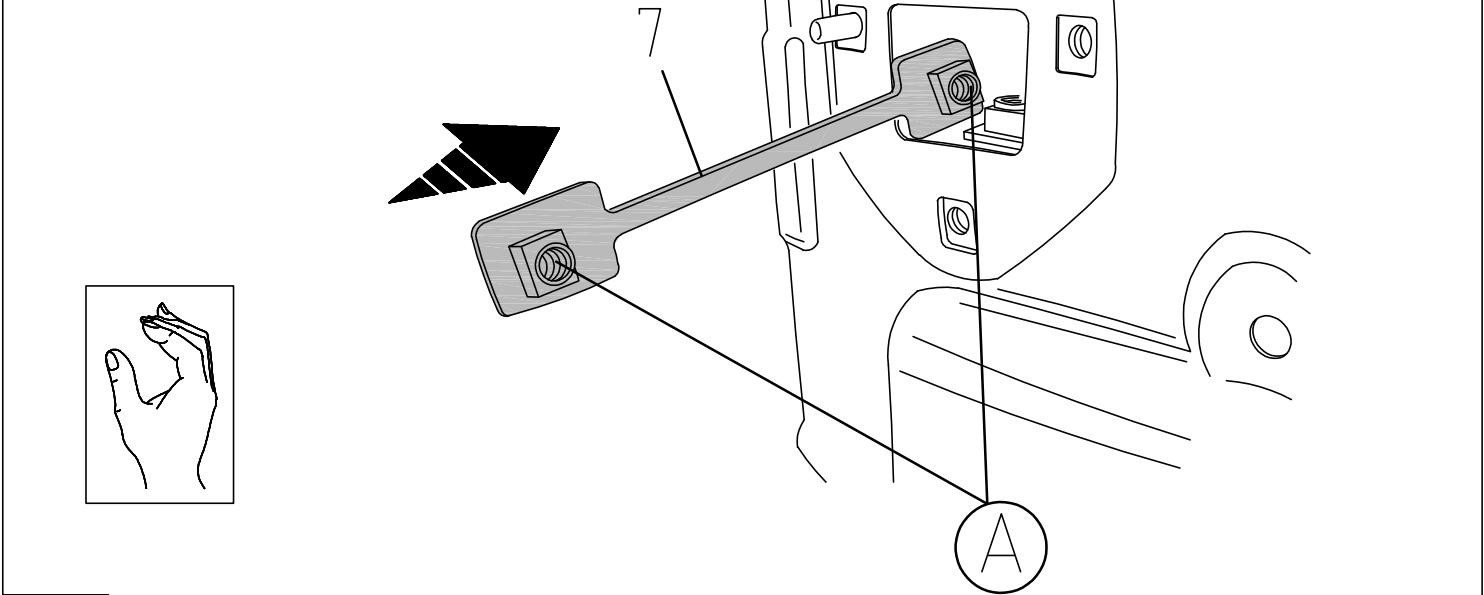
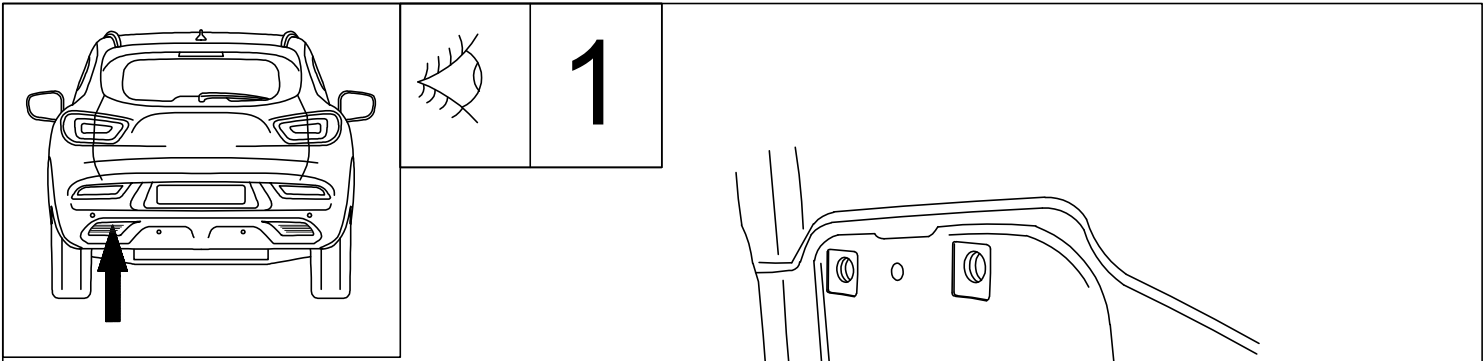

14

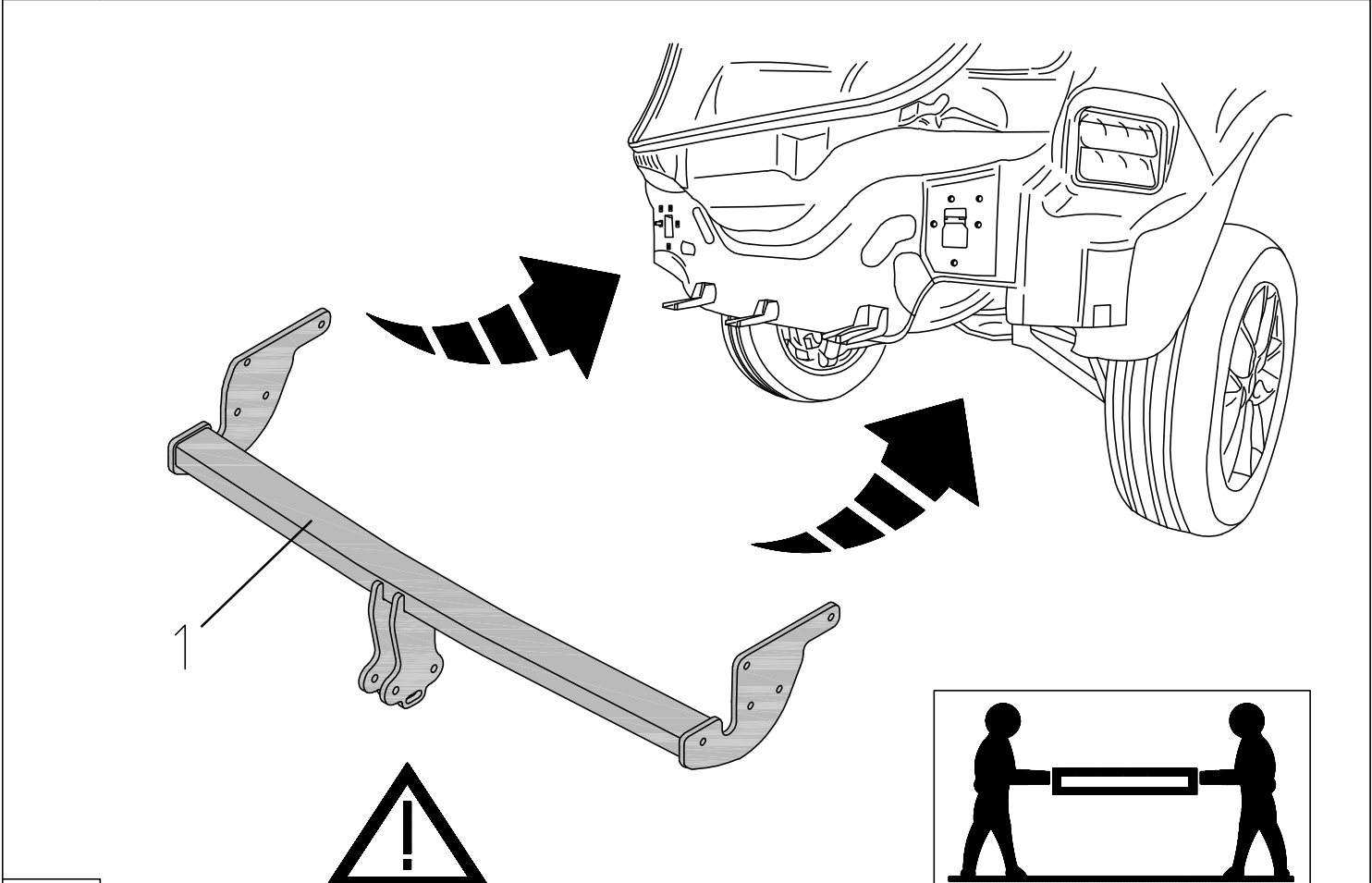

15

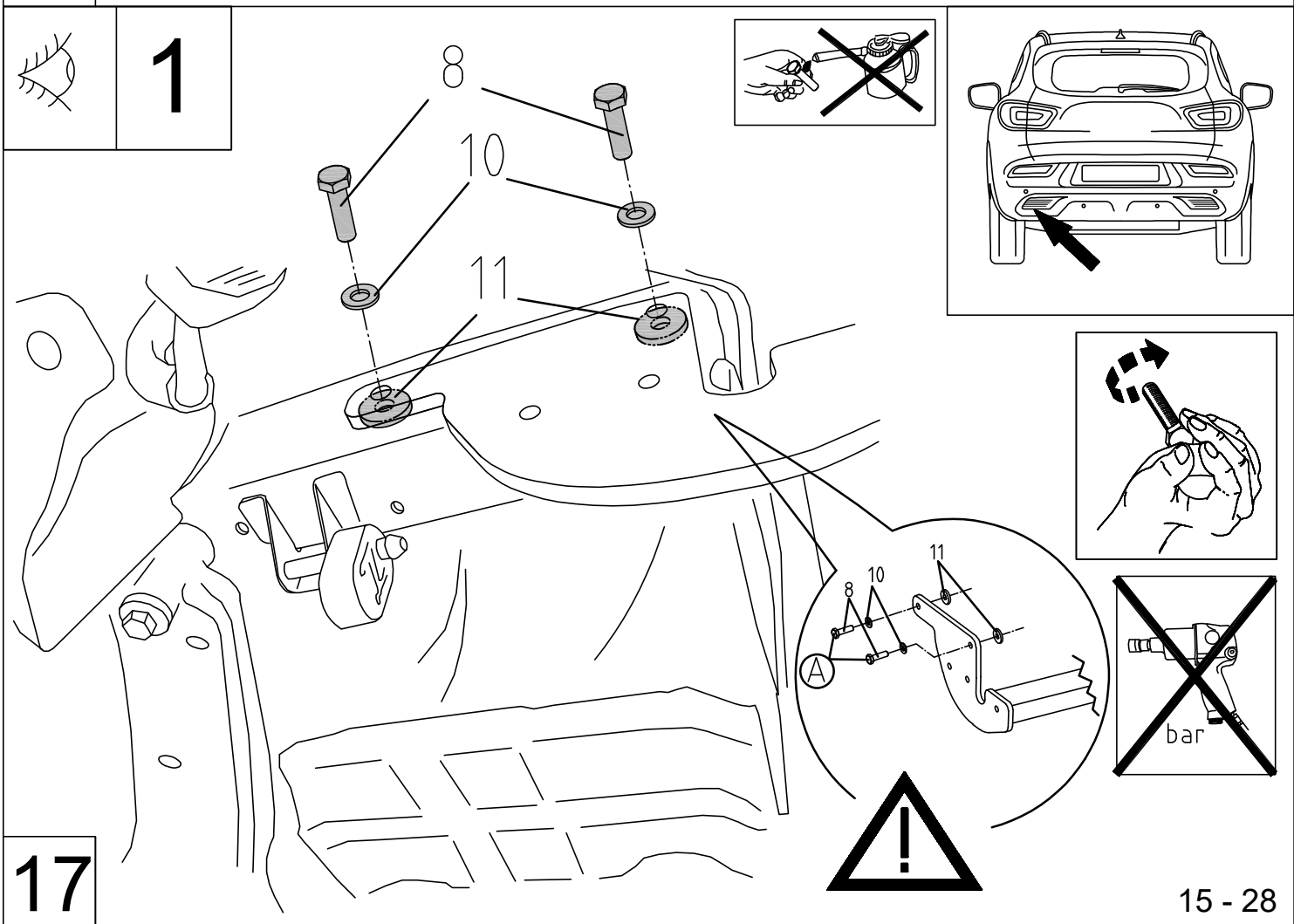
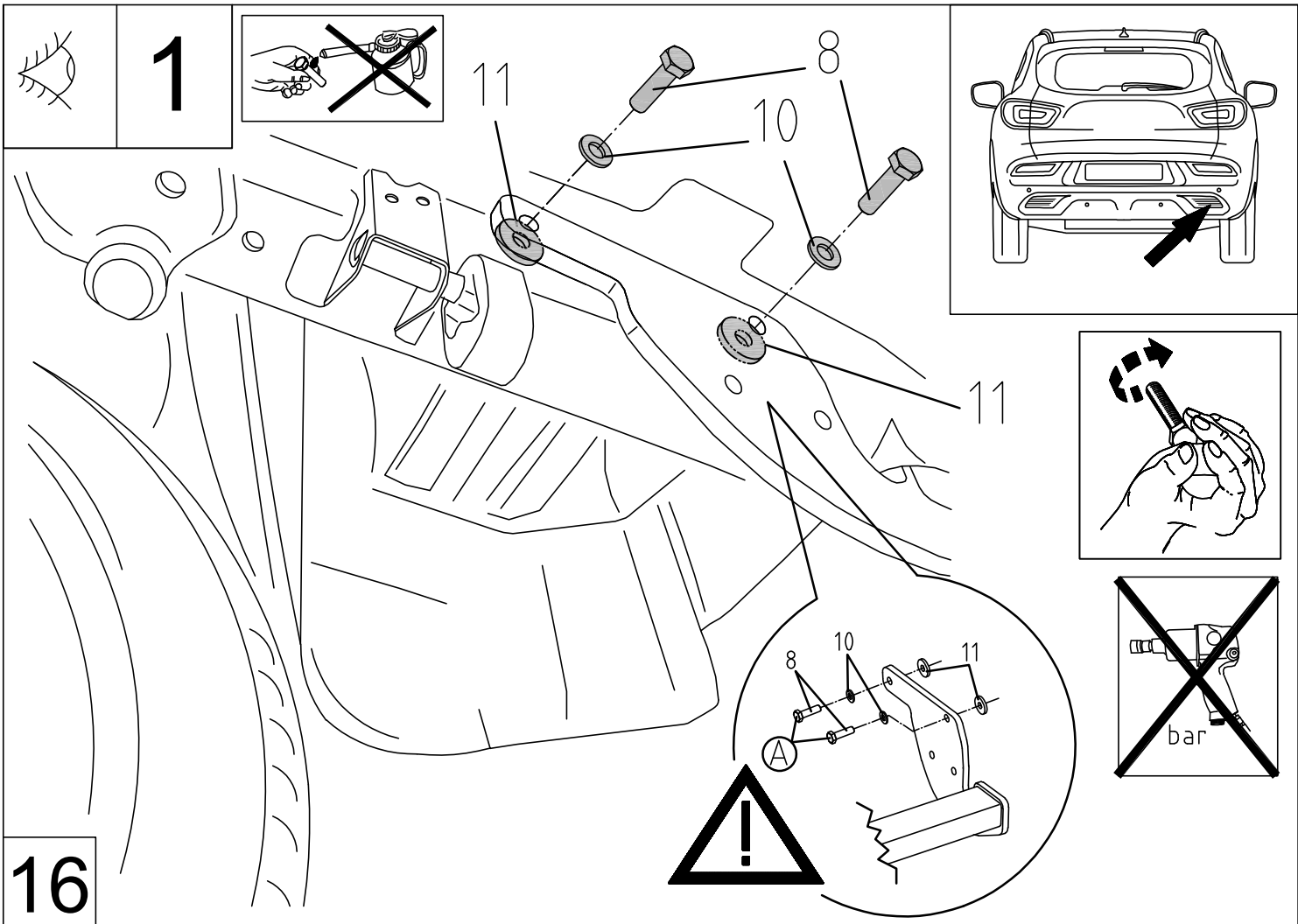

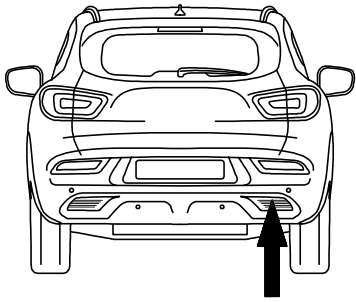

1

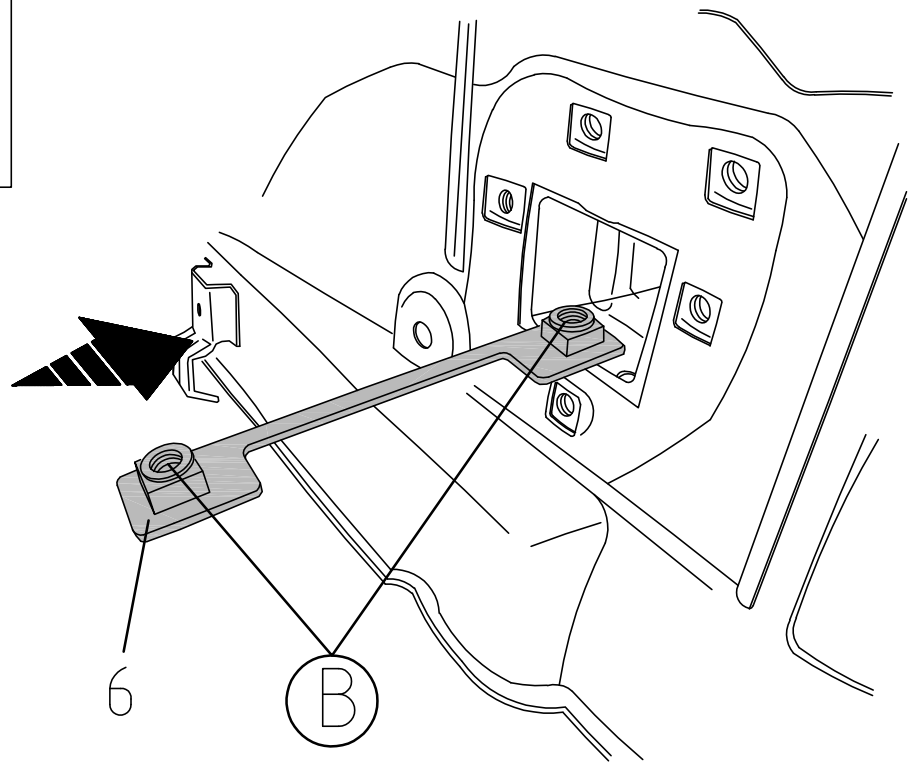

18

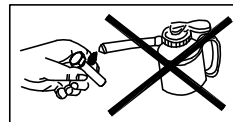
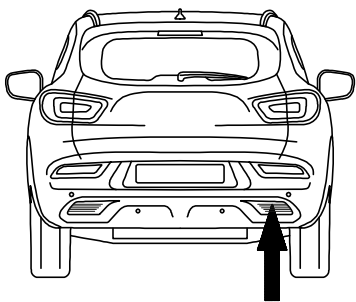

1

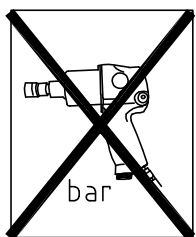
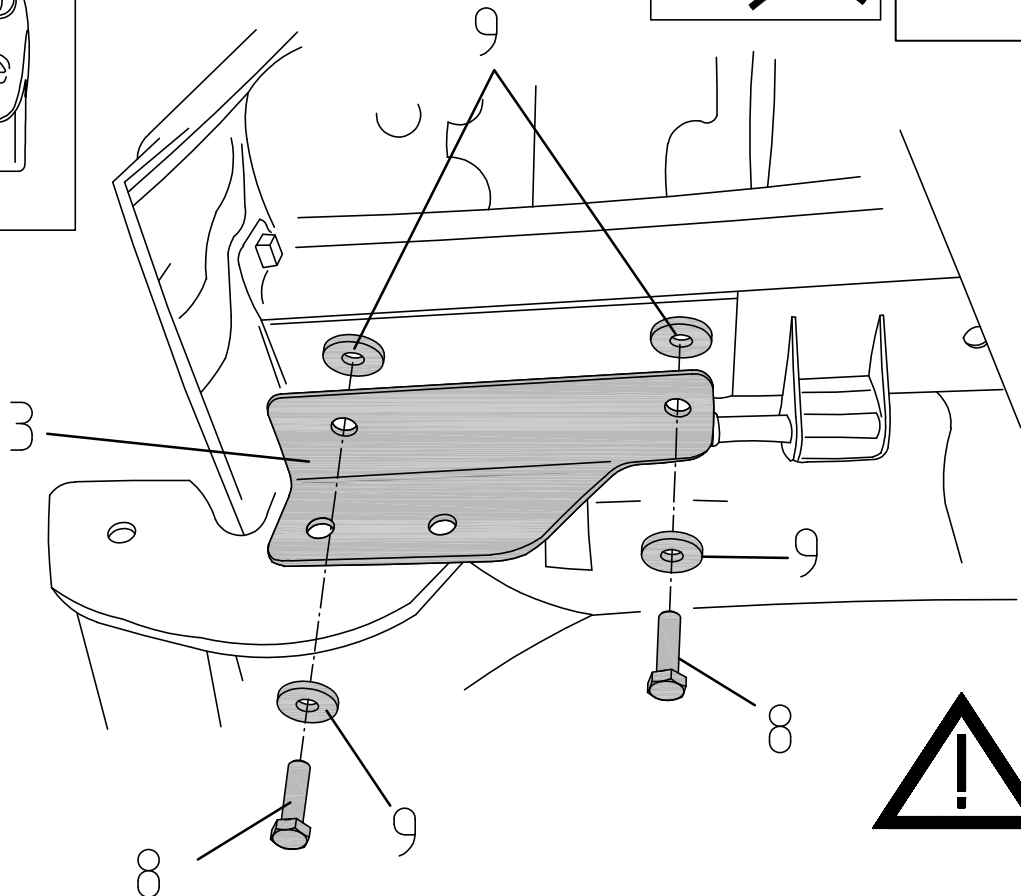
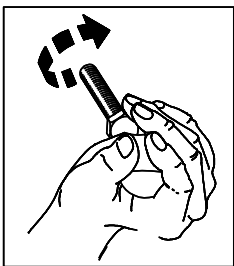

19



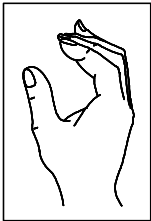
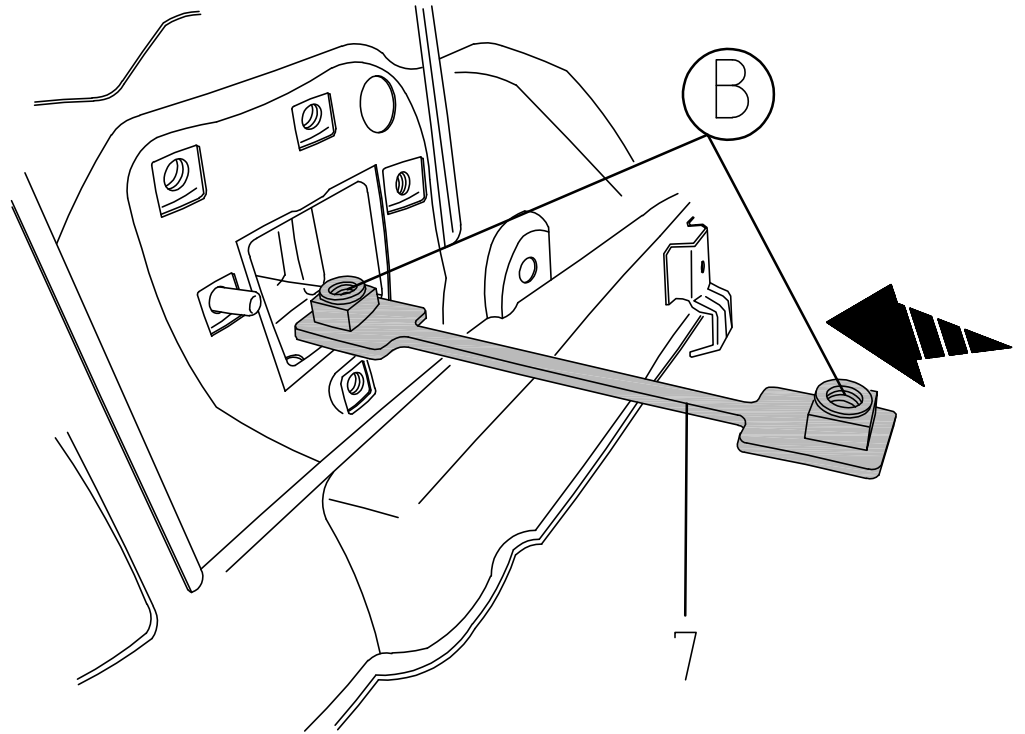
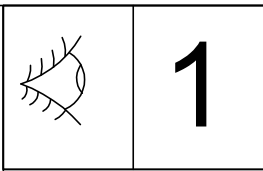
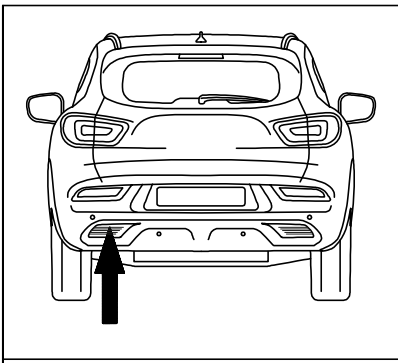

20

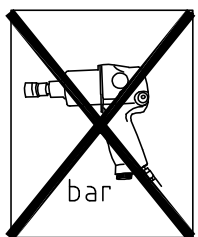
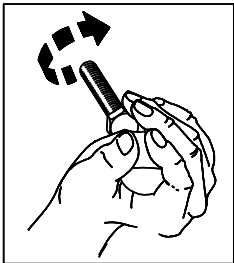
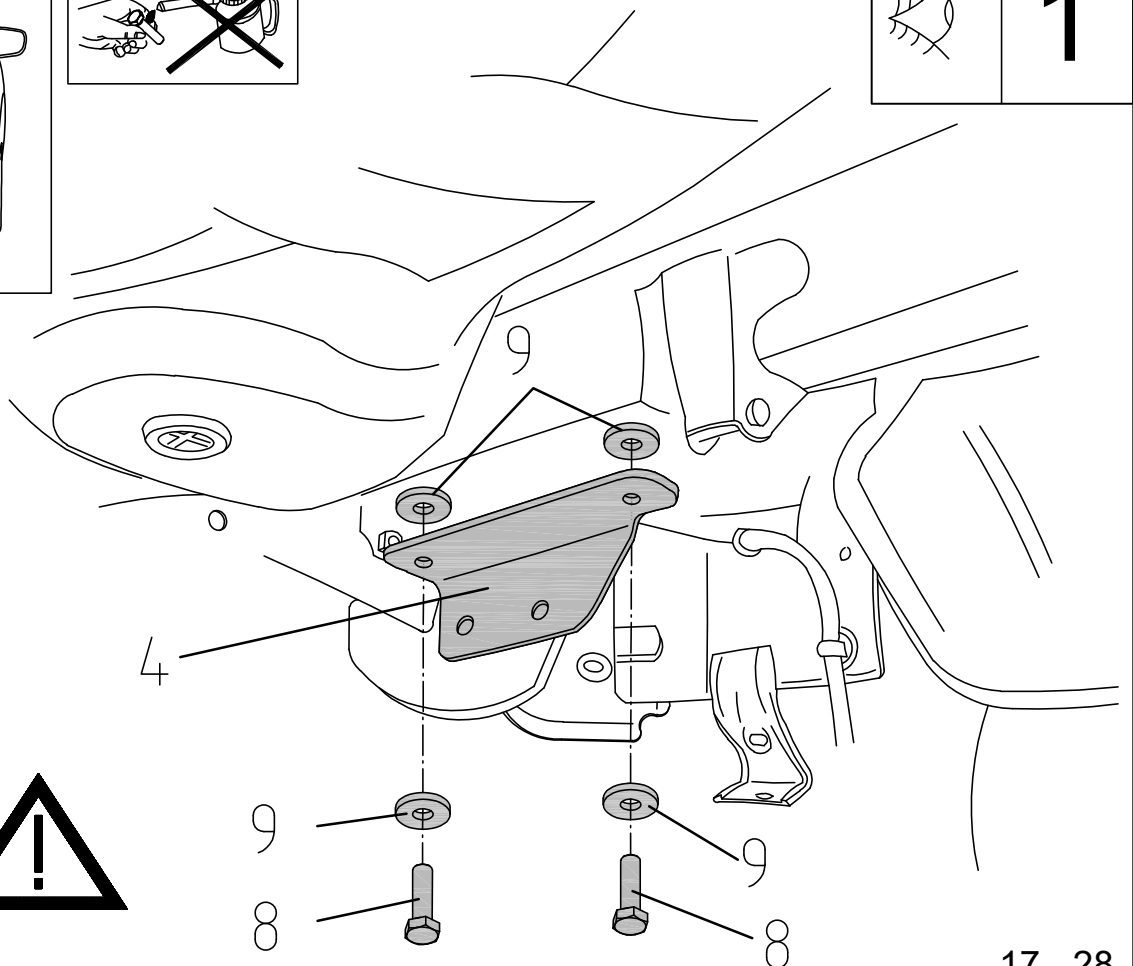
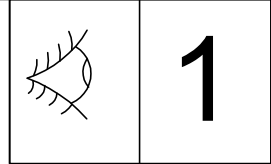
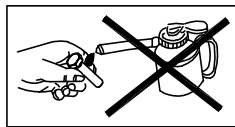
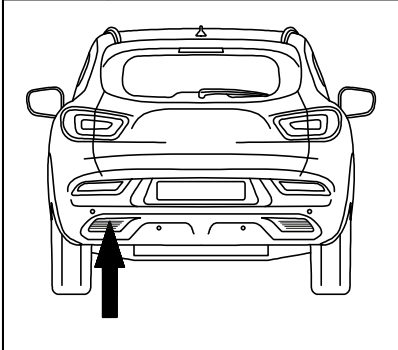

21

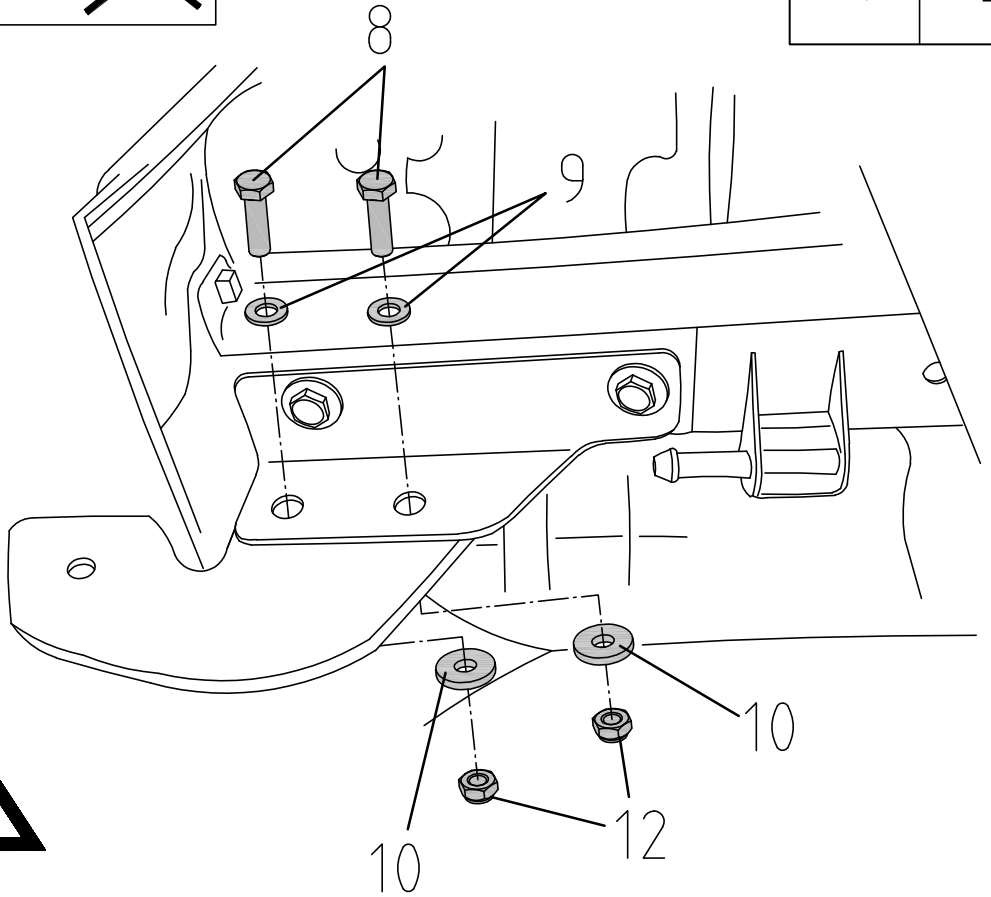
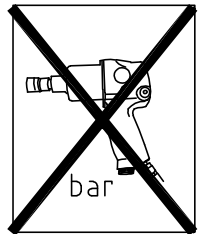
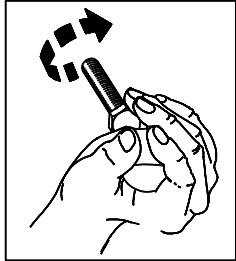
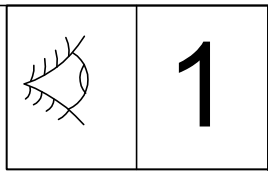
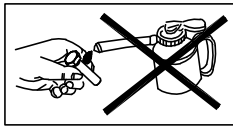
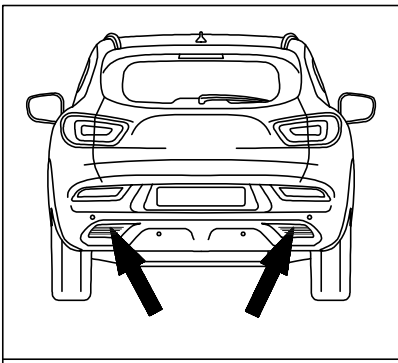

22

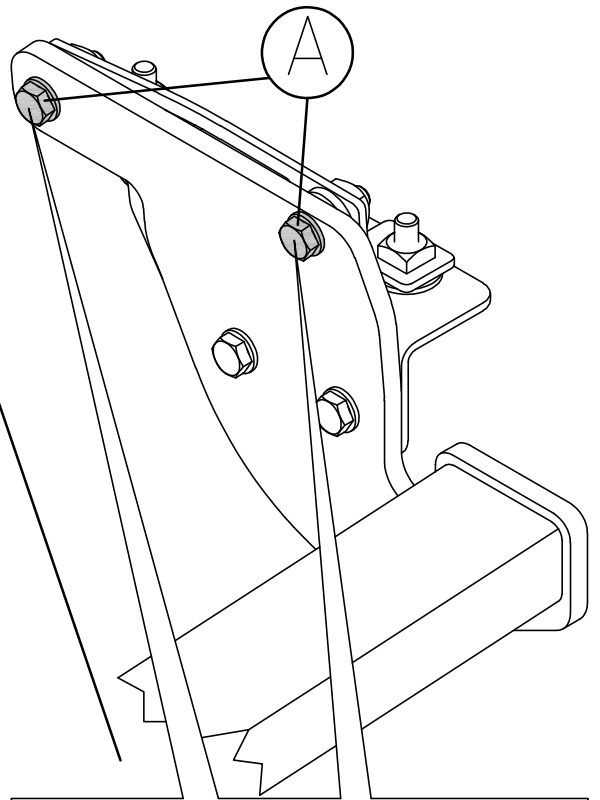
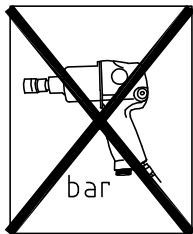
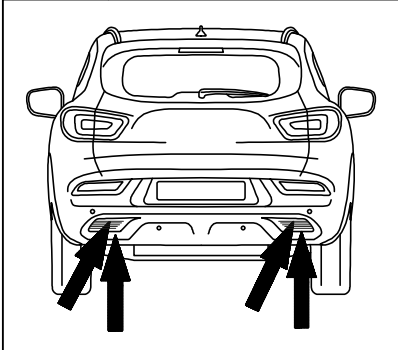

23

	M10	10.9	60Nm
--	-----	------	------

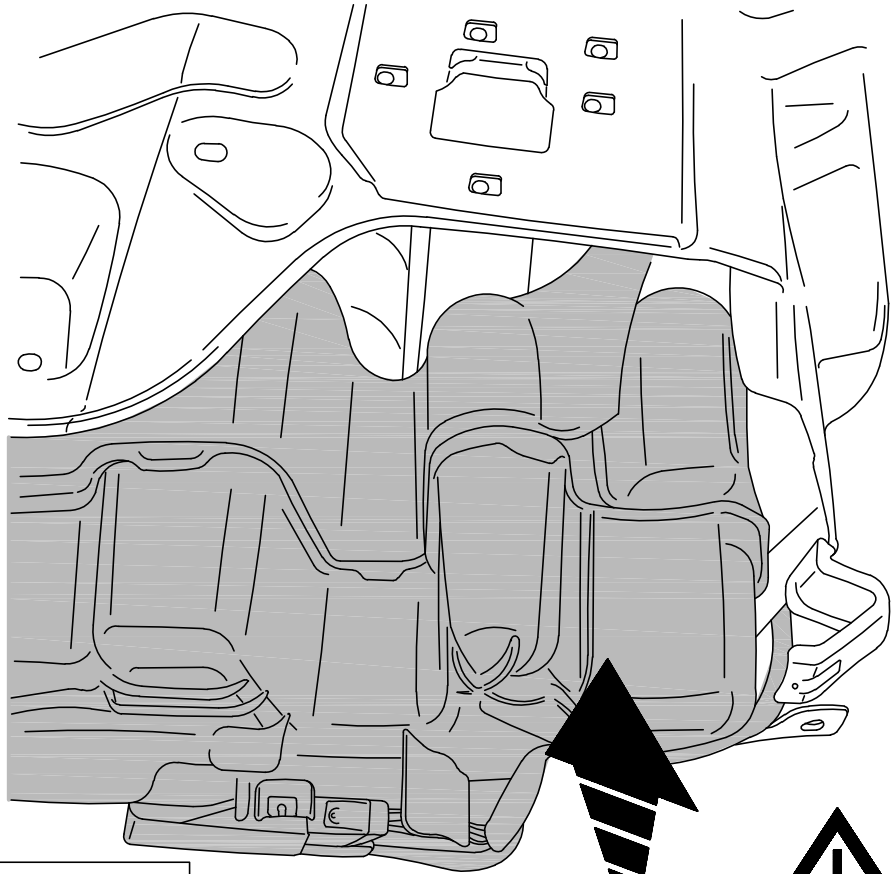
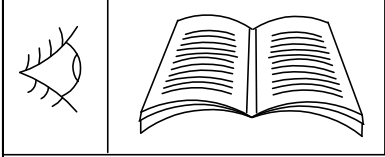
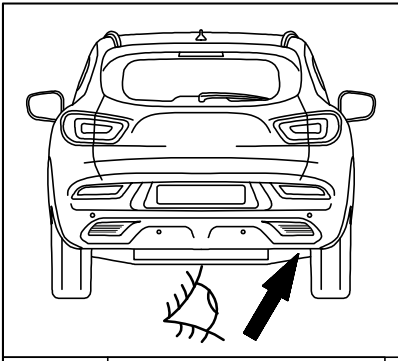

 AdBlue



24

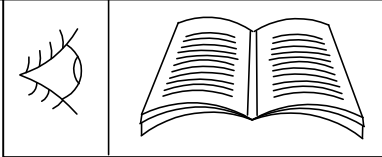
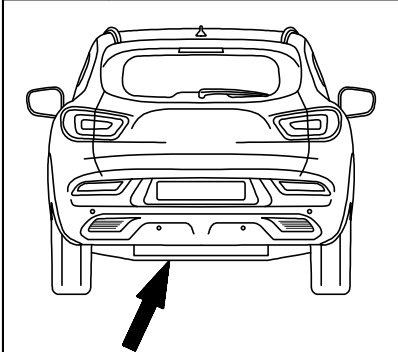

X14

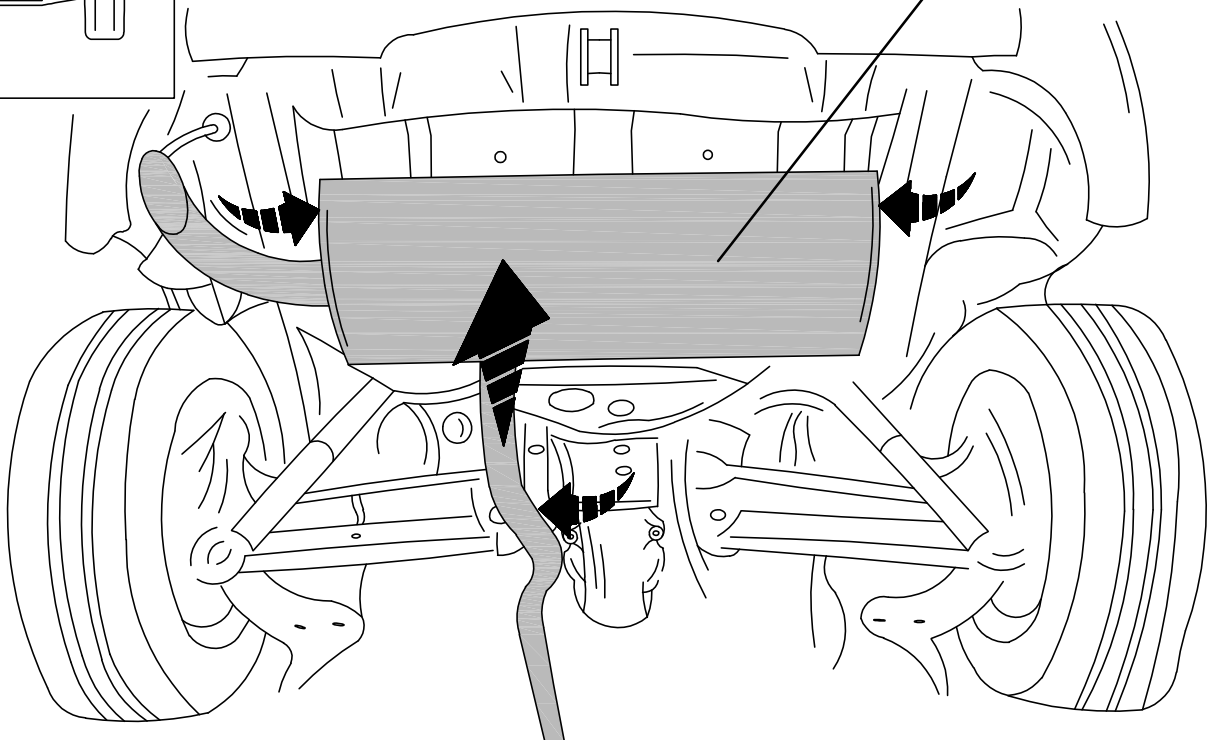

25

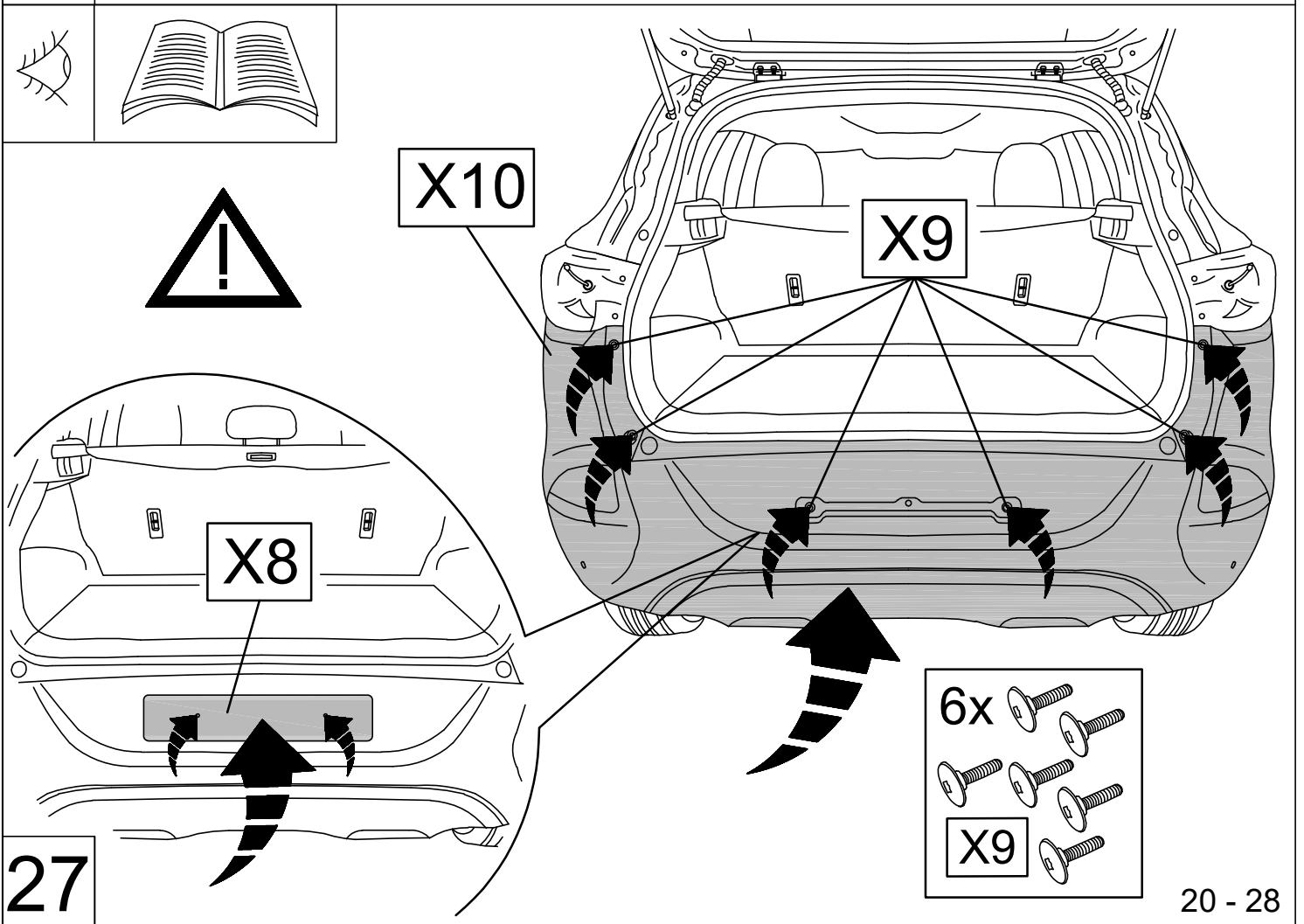
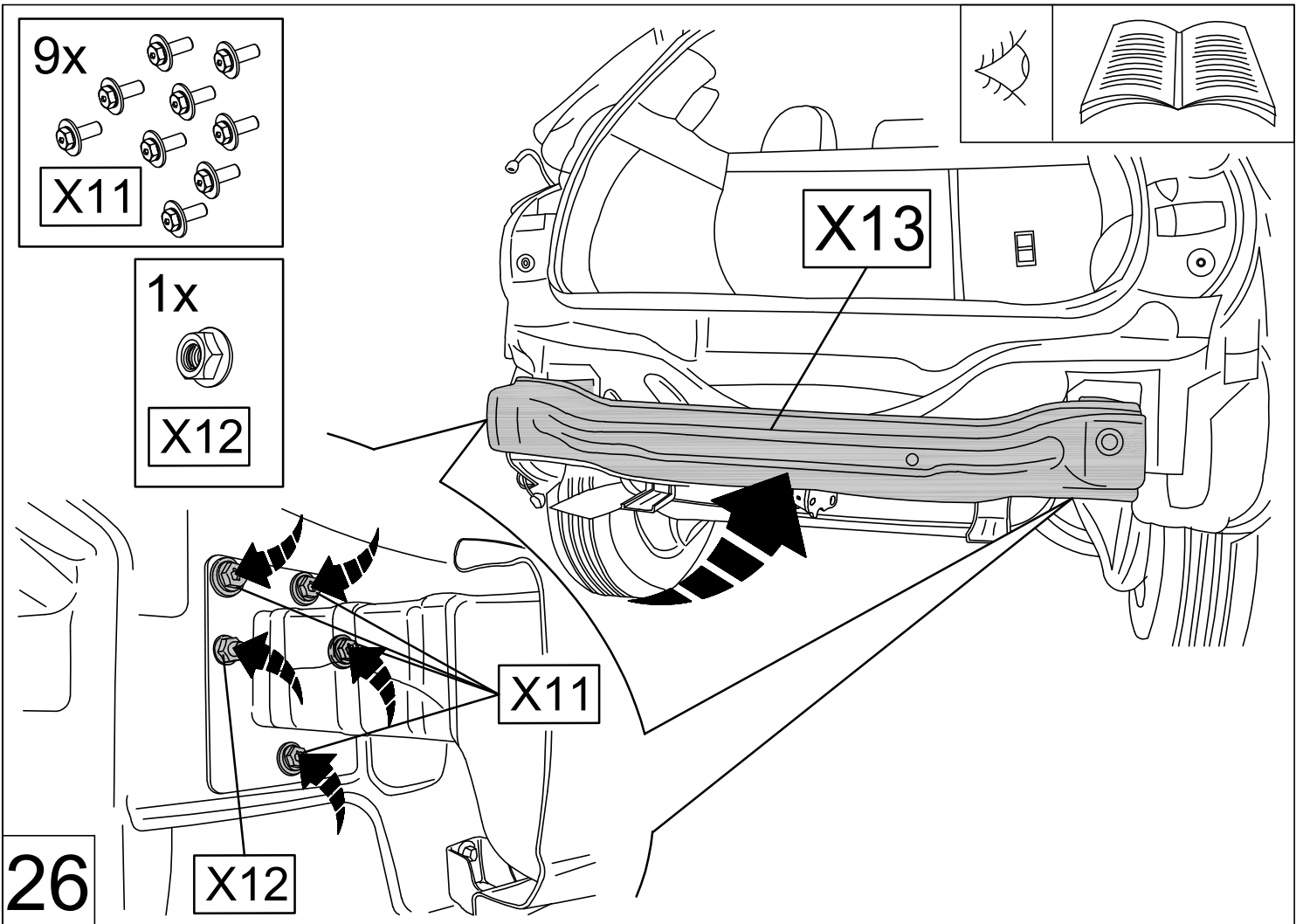

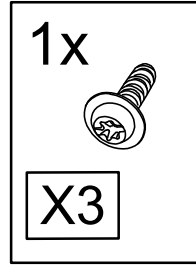
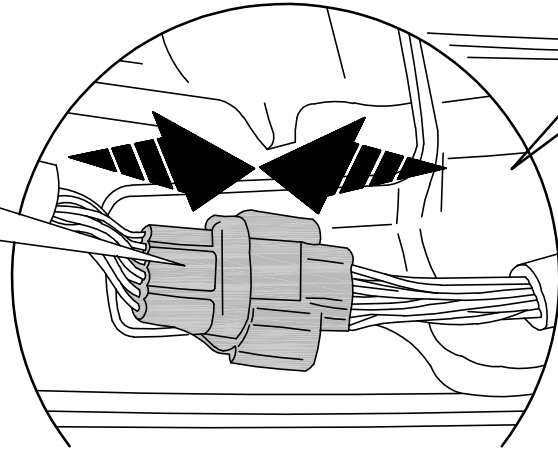
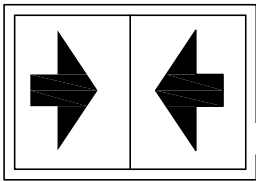
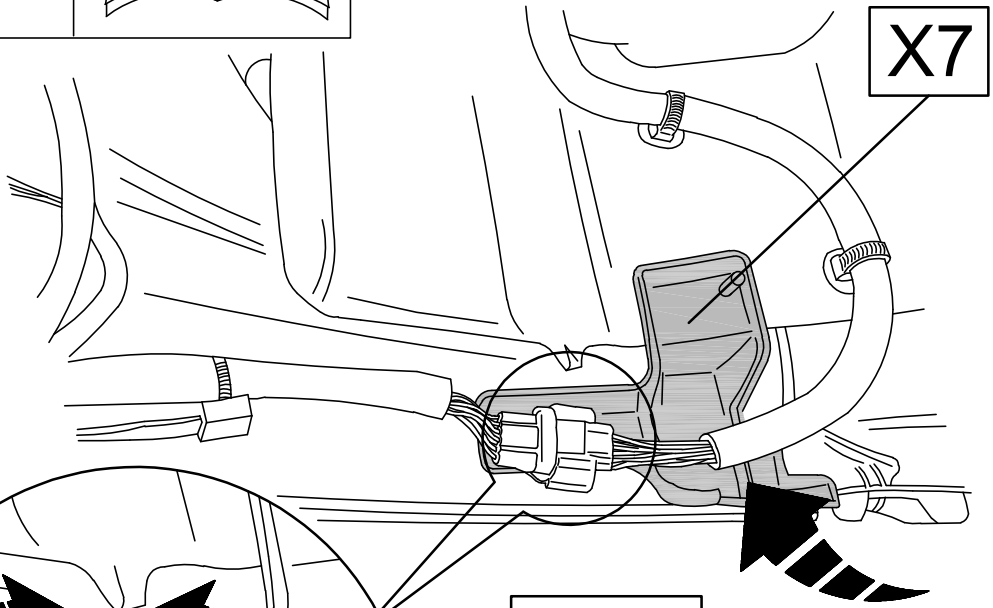
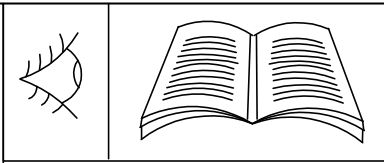
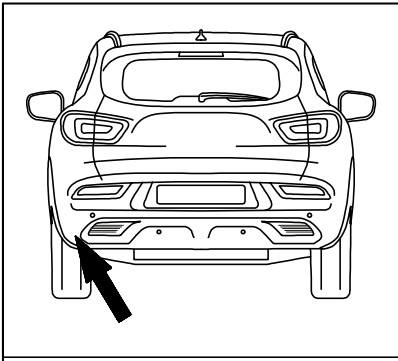

28

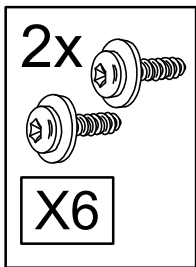
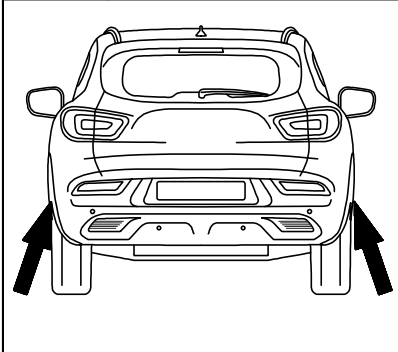

29

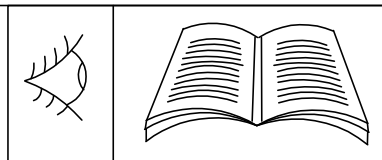
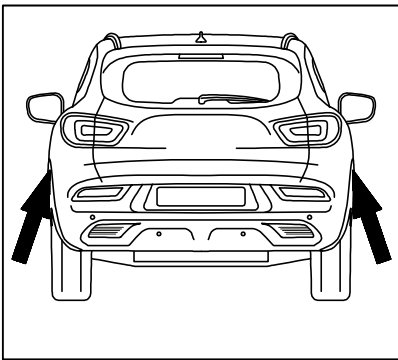

"KLICK"

X7

X5

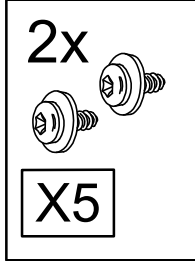

30

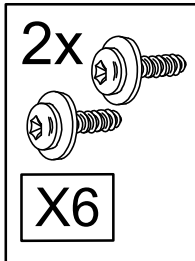
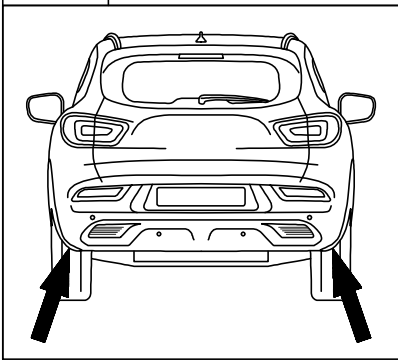

X6

X5

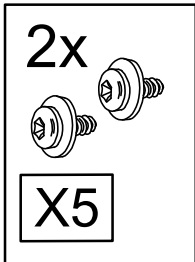

31

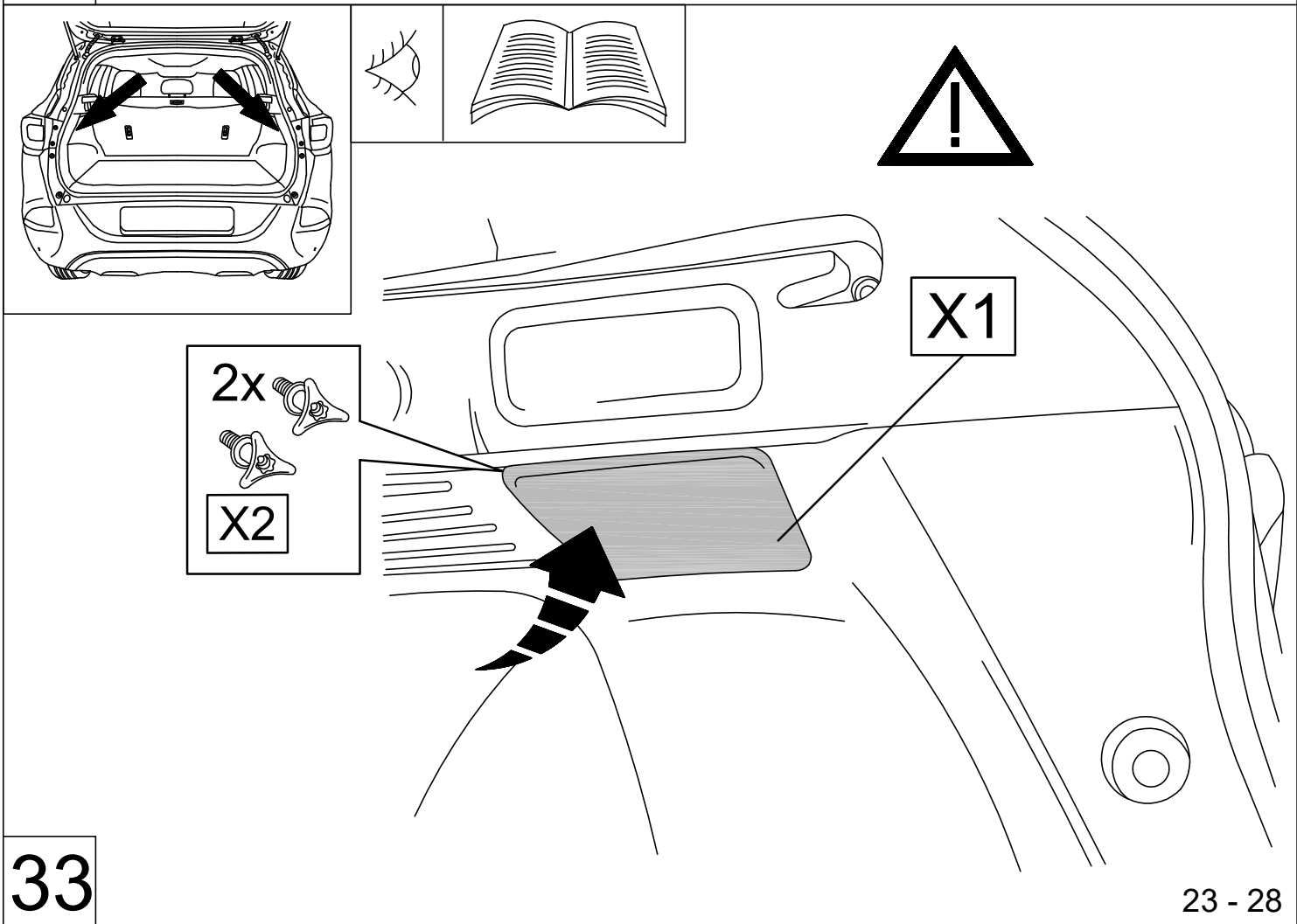
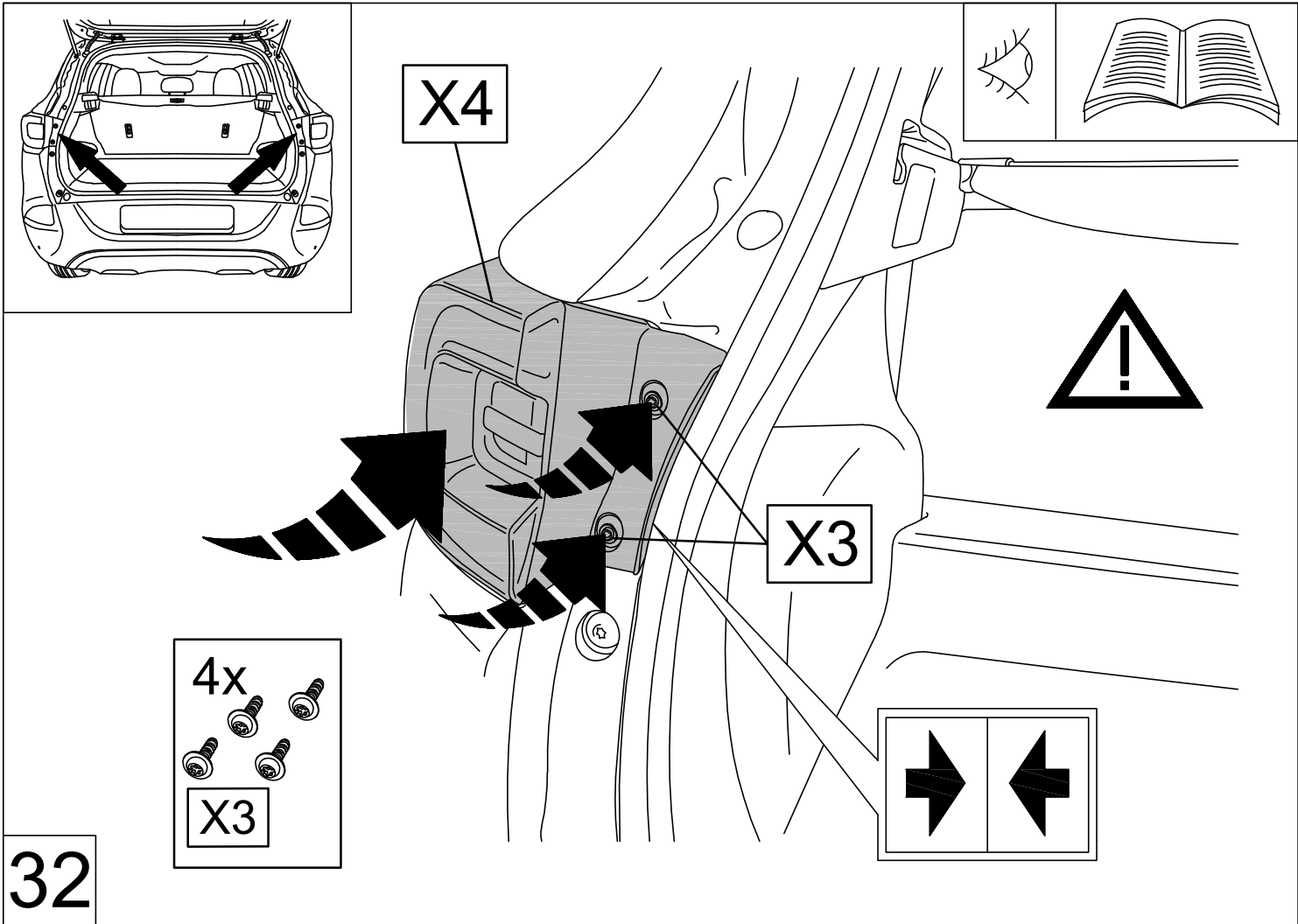

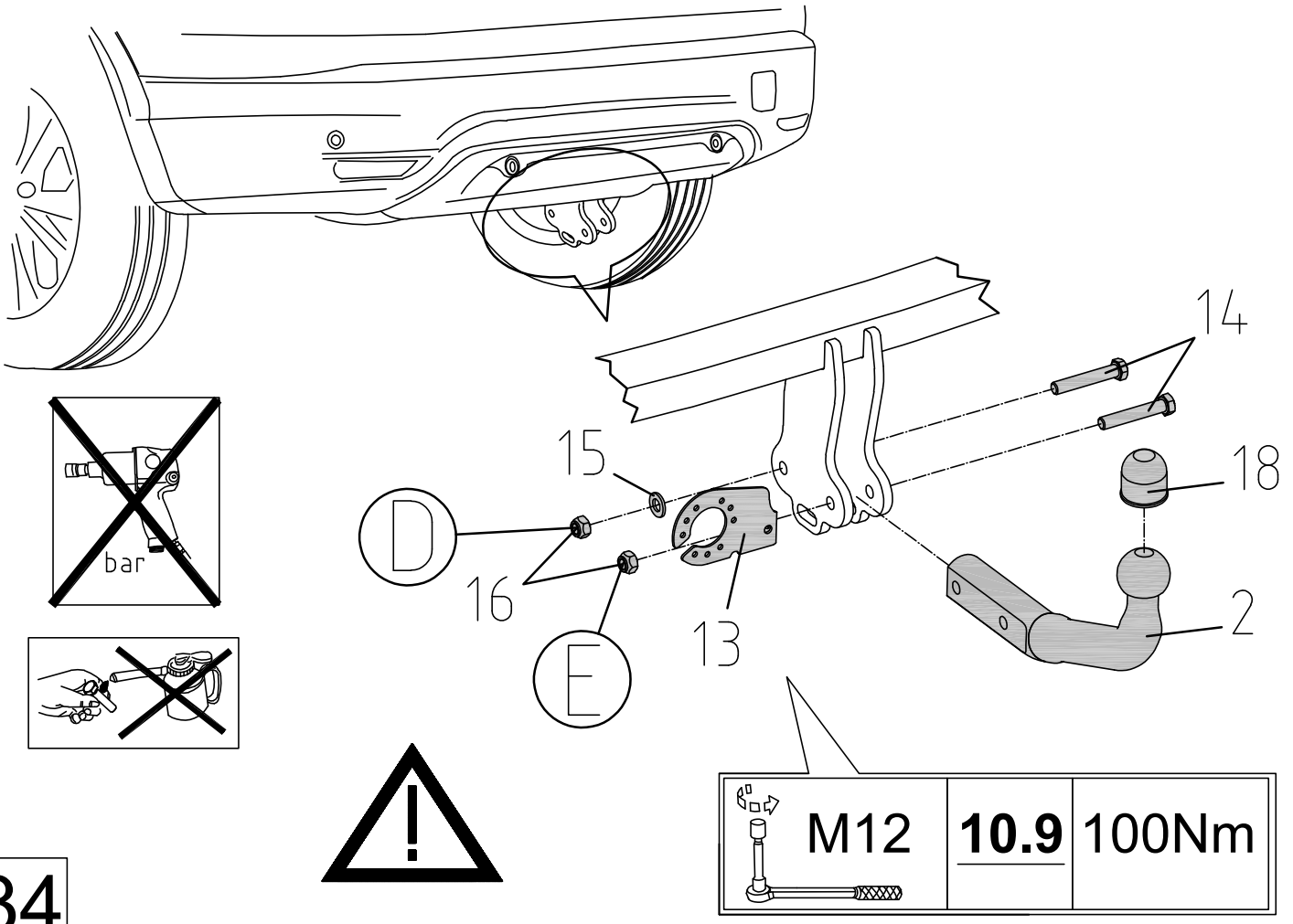

34

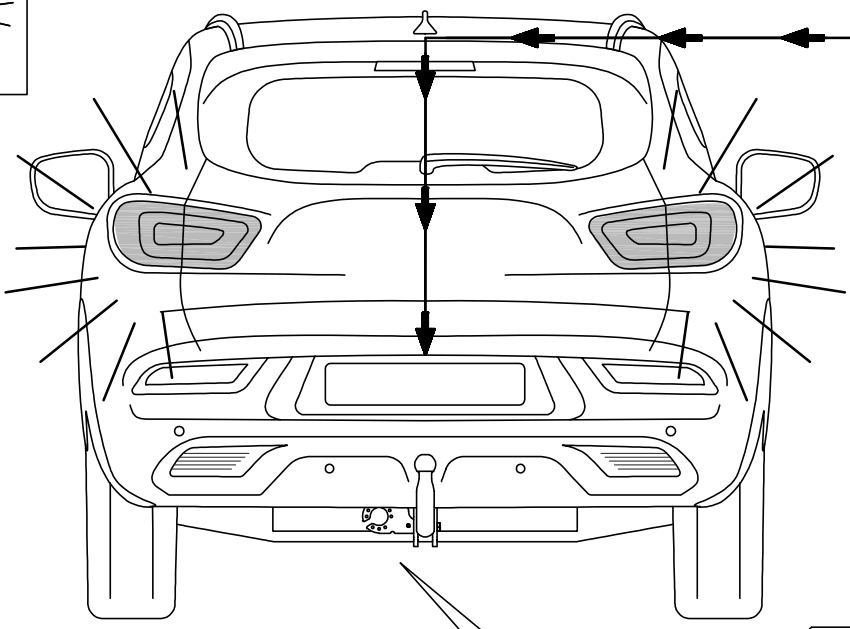
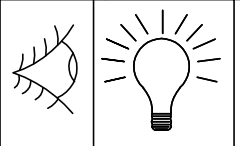

Zulässige Stützlast maximal 75 kg  
  
[www.mvg-ahk.de](http://www.mvg-ahk.de)

19

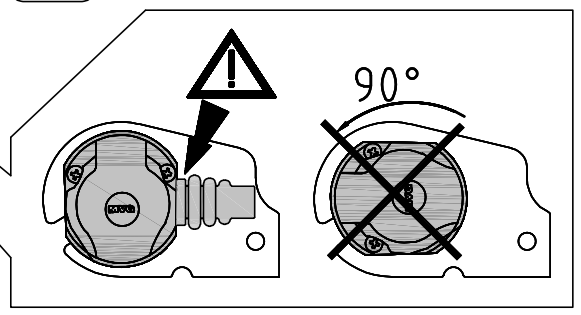

35



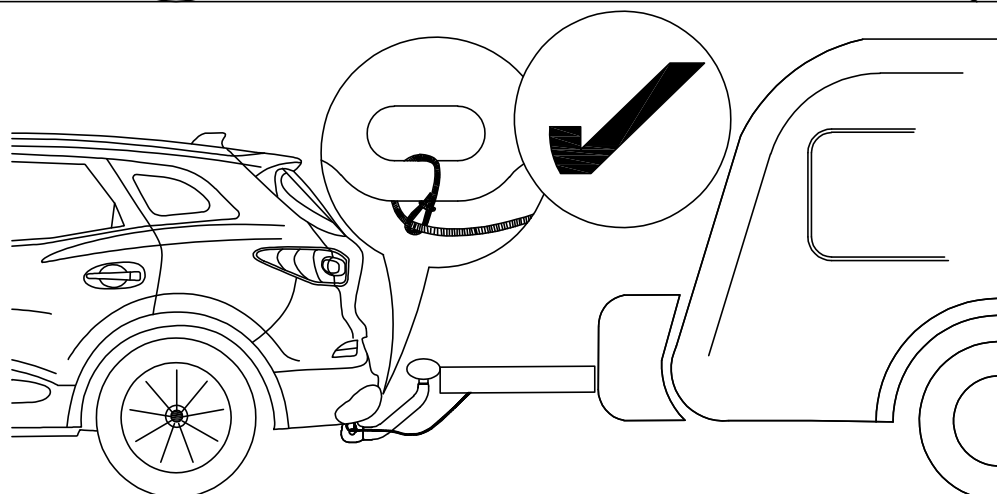
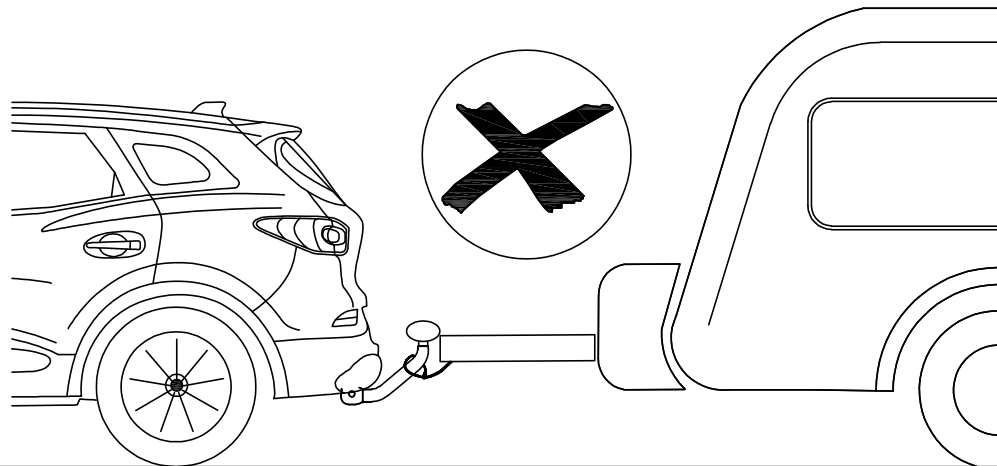

36

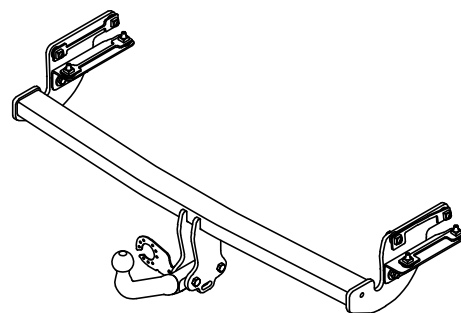
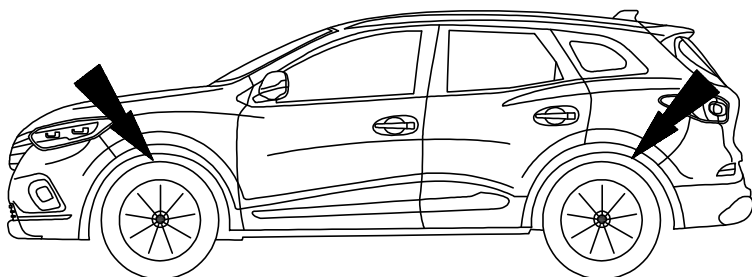

Best. Nr.: 0979 B

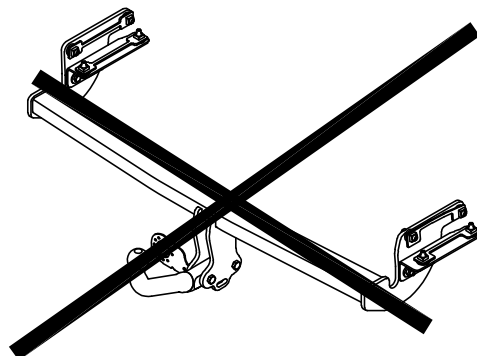
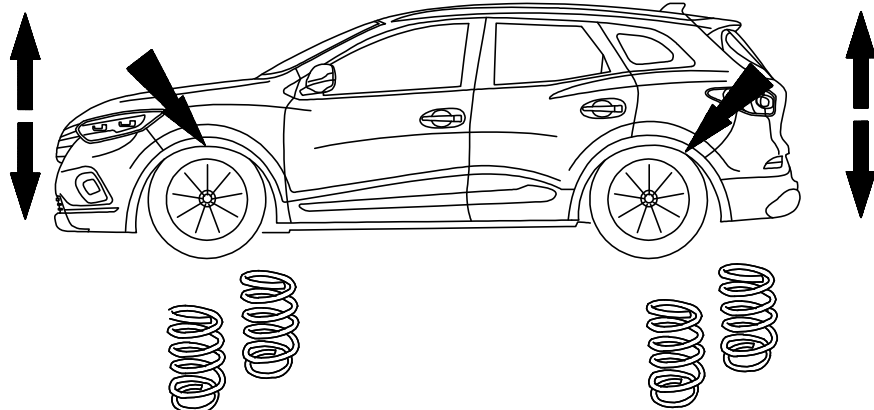

37

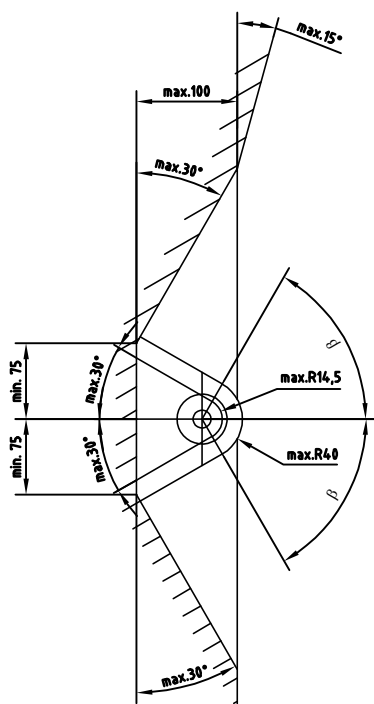
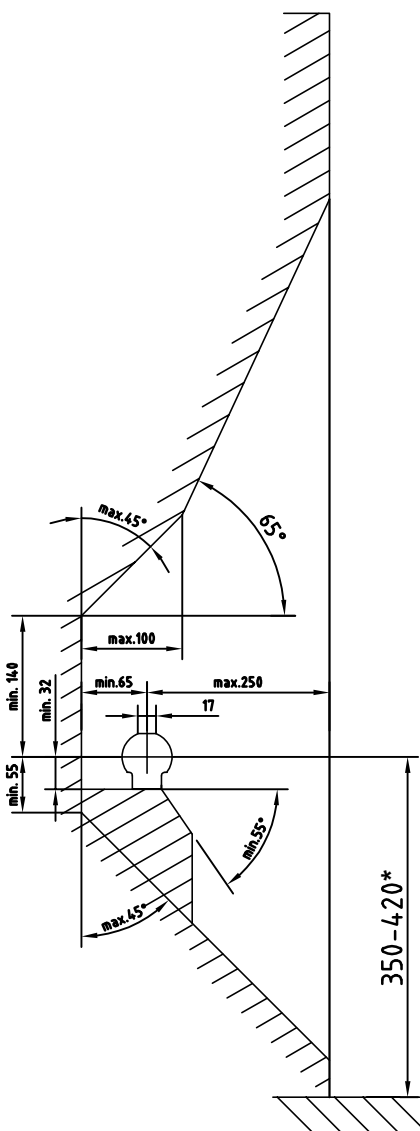

- D** Der Freiraum nach Anhang 7, Abbildung 25a und 25b der Richtlinie ECE-R 55 ist zu gewährleisten.
- CZ** Volný prostor ve smyslu Přílohy 7, obr. 25a a 25b směrnice ECE-R 55 musí být zaručen.
- DK** Det skal sikres, at der er spillerum i overensstemmelse med bilag 7, fig. 25a og 25b i henhold til direktiv ECE-R 55.
- E** Hay que garantizar el espacio libre conforme al anexo 7, fig. 25a y 25b de la directiva ECE-R 55.
- F** La zone de dégagement, selon l'annexe 7, figure 25a et 25b de la directive ECE-R 55, doit être assurée.
- FIN** Välyksen tulee täyttää ohjeen ECE-R 55 liitteen 7 kuvissa 25a ja 25b ilmoitetut vaatimukset.
- GB** Make sure to provide clearance according to appendix 7, figures 25a and 25b of the ECE-R 55 regulations.
- GR** Πρέπει να εξασφαλίζεται ο ελεύθερος χώρος σύμφωνα με το παράρτημα 7, σχήμα 25a και 25b της κοινοτικής οδηγίας ECE-R 55.
- H** Biztosítani kell az ECE-R 55 irányelv szerinti, 7. számú függelék, 25a. és 25b ábrákban jelölt szabad teret.
- I** Deve essere garantito lo spazio libero secondo l'allegato 7, figure 25a e 25b della normativa europea ECE-R 55.
- N** Det må sørges for fritt rom i samsvar med tillegg 7, figur 25a og 25b i direktiv ECE-R 55.
- NL** De vrije ruimte volgens supplement 7, afbeelding 25a en 25b van richtlijn ECE-R 55 moet gewaarborgd zijn.
- PL** Należy zapewnić wolną przestrzeń zgodnie z załącznikiem 7, rys. 25a i 25b, dyrektywy ECE-R 55.
- RUS** Оставлять свободное пространство согласно Приложению 7, рис. 25a и 25b Директивы ECE-R 55.
- S** Spelrummet enligt bilaga 7, bild 25a och 25b i riktlinje ECE-R 55, måste garanteras.

- D** \* bei zulässigem Gesamtgewicht des Fahrzeuges
- CZ** \* při celkové přípustné hmotnosti vozidla
- DK** \* ved tilladt totalvægt for køretøjet
- E** \* con peso total autorizado del vehículo
- F** \* pour poids total en charge autorisé du véhicule
- FIN** \* Ajoneuvon suurimmalla sallitulla kokonaispainolla
- GB** \* at gross vehicle weight rating
- GR** \* για το επιτρεπτό μικτό βάρος του οχήματος
- H** \* A jármű megengedett összsúlya esetén
- I** \* per il peso complessivo ammesso del veicolo
- N** \* ved kjøretøyets tillatte totalvekt
- NL** \* bij toegestaan totaal gewicht van het voertuig
- PL** \* przy dopuszczalnym ciężarze całkowitym pojazdu
- RUS** \* при допустимом общем весе автомобиля
- S** \* vid fordonets tillåtna totalvikt

- D** Die Anhängervorrichtung ist ein Sicherheitsteil und darf nur von Fachunternehmen montiert werden. Bei falscher Montage besteht schwere Unfallgefahr! Der deutsche Text dieser Anleitung ist bindend.
- CZ** Tažné zařízení je bezpečnostní součást, kterou smí montovat pouze odborné podniky. Při chybné montáži hrozí vážné nebezpečí nehody! Německý text tohoto návodu je závazný.
- DK** Anhængertrækket er en sikkerhedsdel og må kun monteres af autoriserede firmaer. Ved forkert montering er der fare for alvorlige uheld! Den tyske tekst i denne vejledning er bindende.
- E** La bola de enganche es un elemento de seguridad y sólo se debe permitir su montaje a personal cualificado. ¡En caso de montaje erróneo existe peligro de accidentes graves! Es vinculante el texto alemán de estas instrucciones.
- F** Le dispositif d'attelage est un équipement de sécurité et doit être mis en place exclusivement par un atelier spécialisé. Un montage incorrect représente un risque élevé d'accident! Le texte allemand de cette notice fait foi.
- FIN** Vetolaite on turvallisuu-teen vaikuttava osa, jonka saa asentaa vain alan erikoisliike. Virheellinen asennus voi aiheuttaa vakavan onnettomuuden! Tämän ohjeen saksankielinen teksti on sitova.
- GB** A trailer hitch is a safety-critical part and may be fitted only by qualified companies. Improper assembly may result in a serious accident hazard! The German text of this instruction is binding.
- GR** Ο κοτσαδόρος είναι ένα εξάρτημα ασφαλείας και η τοποθέτηση του επιτρέπεται να γίνεται μόνο από εξειδικευμένο συνεργείο. Σε περίπτωση λάθους τοποθέτησης υπάρχει κίνδυνος σοβαρών ατυχημάτων! Το γερμανικό κείμενο αυτών των οδηγιών είναι δεσμευτικό.
- H** A vonószerkezet egy biztonsági felszerelés, amelyet csak szaküzem szerelhet fel. Helytelen szerelés súlyos balesethez vezethet! A német szerelési utasítás betartása kötelező.
- I** Il gancio di traino è un componente di sicurezza e deve essere montato esclusivamente da personale specializzato. In caso di montaggio errato sussiste il pericolo di incidenti gravi! È vincolante il testo tedesco di queste istruzioni.
- N** Tilhengerfestet er en sikkerhetskompone-nt og skal monteres av fagbedrift. Det er stor fare for at det kan oppstå ulykker ved feil montering! Den tyske teksten i denne veiledningen er bindende.
- NL** De aanhanger is veiligheids-onderdeel en mag alleen door vakkundig personeel worden gemonteerd. Bij verkeerde montage bestaat ernstig gevaar voor ongevallen! De Duitse tekst van deze handleiding is bindend.
- PL** Hak holowniczy stanowi element bezpieczeństwa i może zostać zamontowany wyłącznie przez firmę specjalistyczną. W przypadku nieprawidłowego montażu istnieje poważne ryzyko wypadku! Tekst niniejszej instrukcji w języku niemieckim jest wiążący.
- RUS** Сцепное устройство - это узел, несущий предохранительные функции, и к его монтажу допускаются только специалисты. При неправильном монтаже грозит опасность тяжелых травм! Обязательным является немецкий текст данной инструкции.
- S** Dragkroken är en säkerhetskompone-nt och bör endast monteras av kvalificerade tekniker. Vid felaktig montering föreligger risk för allvariga olyckor! Den tyska texten i denna anvisning är bindande.



Dispositivo di traino tipo: **0979 B**  
Per autoveicoli: **Renault Kadjar**  
Tipo funzionale: **RFE**

Classe e tipo di attacco: **CLASS A50-X**  
Omologazione: **E4 55R-01 1114**  
Valore D: **10,0 kN**  
Carico verticale max. S: **100 kg**

Larghezza rimorchiabile per Caravan e T.A. T.S.: **2,45 m vedere CARTA di CIRCOLAZIONE VEICOLO (motrice) + 70 cm = arrotondare ai 5 cm superiore (vedi D.M. 28/05/85)**  
Massa rimorchiabile: **Vedi carta circolazione dell' autoveicolo**

Per verificare l'idoneità del dispositivo di traino omologato a norma ECE-R55, all'installazione sulla vettura su cui si intende procedere al montaggio, compilare la seguente formula (se necessario declassare la massa rimorchiabile):  
$$D = ((T \times C) / (T+C)) \times 0,00981 = 10,0 \text{ kN} < D$$
  
dove: T = Massa Complessiva Max. della motrice (in kg)  
C = Massa Rimorchiabile Max. della motrice (in kg)

**DA COMPILARE PER IL COLLAUDO**

DICHIARAZIONE DI CORRETTO MONTAGGIO: la sottoscritta Ditta dichiara di aver montato in maniera corretta ed in conformità alle prescrizioni sia del costruttore del veicolo che del costruttore del dispositivo stesso il seguente dispositivo di attacco meccanico:

Tipo: .....  
Il dispositivo di attacco sopra indicato è stato installato su autoveicolo  
Modello: .....  
Targa: .....  
Data: .....

TIMBRO e FIRMA

Si dichiara inoltre di aver informato l'utente del veicolo sull'USO e MANUTENZIONE del dispositivo stesso.